



Product Documentation

ER/Studio® Data Architect

Evaluation Guide

2nd Edition

Version 8.5.3

Published June 2010

© 2010 Embarcadero Technologies, Inc. Embarcadero, the Embarcadero Technologies logos, and all other Embarcadero Technologies product or service names are trademarks or registered trademarks of Embarcadero Technologies, Inc. All other trademarks are property of their respective owners.

Embarcadero Technologies, Inc. is a leading provider of award-winning tools for application developers and database professionals so they can design systems right, build them faster and run them better, regardless of their platform or programming language. Ninety of the Fortune 100 and an active community of more than three million users worldwide rely on Embarcadero products to increase productivity, reduce costs, simplify change management and compliance and accelerate innovation. The company's flagship tools include: Embarcadero® Change Manager™, CodeGear™ RAD Studio, DBArtisan®, Delphi®, ER/Studio®, JBuilder® and Rapid SQL®. Founded in 1993, Embarcadero is headquartered in San Francisco, with offices located around the world. Embarcadero is online at www.embarcadero.com.

June 9, 2010

CORPORATE HEADQUARTERS

100 CALIFORNIA STREET
12TH FLOOR
SAN FRANCISCO, CALIFORNIA
94111 USA

EMEA HEADQUARTERS

YORK HOUSE
18 YORK ROAD
MAIDENHEAD, BERKSHIRE
SL6 1SF, UNITED KINGDOM

ASIA-PACIFIC HEADQUARTERS

L7. 313 LA TROBE STREET
MELBOURNE VIC 3000
AUSTRALIA

Contents

- Introduction 1
- Getting Started with ER/Studio Data Architect 4
- Logical and Physical Modeling 6
- Documenting an Existing Database 22
- Documenting Data Lineage 32
- Diagram Navigation and Aesthetics 41
- Importing and Exporting Metadata 48
- Dimensional Modeling 52
- Automating Tasks 57
- Collaborative Modeling 61
- Additional Evaluation Resources 86

CONTENTS

INTRODUCTION

ER/Studio Data Architect, previously known as ER/Studio, is a visual modeling application used for platform-independent, logical data architecture analysis and design in addition to platform-specific physical database design and construction. Its powerful, multi-level design environment addresses the everyday needs of database administrators, developers, and data architects who build and maintain large, complex database applications and strive to consolidate, report, and re-use metadata across the enterprise.

The system's progressive interface and simplicity have been designed to effectively address the ease-of-use issues that have plagued data modeling and CASE tools for the past decade and more. The application equips you to create, understand, and manage the life-cycle of mission-critical database designs and business metadata within the enterprise.

The product offers strong logical design capabilities. From one logical design you can spawn many physical designs. ER/Studio Data Architect (ER/Studio DA) offers bidirectional model comparison and information synchronization. It is rich and customizable. You can use Visual-Basic for Applications API for product customization. ER/Studio DA also offers powerful DDL reverse engineering and generation, metadata import and export capabilities, and sophisticated HTML and RTF-based documentation and reporting facilities.

PRODUCT BENEFITS BY AUDIENCE

Data Modelers and Data Architects

ER/Studio DA is critical for organizations concerned with eliminating data redundancy, creating an enterprise view of data assets and assisting development with making informed decisions about how best to reuse elements pre-defined by the enterprise. Its powerful logical (non-database or technology-specific) analysis and design environment helps to normalize and create an enterprise view of the objects concerning the data managed by an organization. More importantly, it can communicate this quickly through powerful reporting and metadata exchange mechanisms throughout the enterprise.

Database Administrators and Database Developers

Managing databases can be incredibly difficult without a blue print or road map to understand important object dependencies. ER/Studio DA's round-trip engineering capabilities, including database reverse-engineering, provide database administrators (DBAs) or developers with important physical data models in seconds. These models can be used as powerful and efficient change management platforms, allowing users to update a model when changes need to be implemented at the database level. The model can then be used to automatically generate DBMS-specific, syntactically correct alteration or database DDL.

Business and IT Managers

ER/Studio DA's robust reporting facilities allow delivery of critical information about designs to the enterprise in seconds. This heavily leveraged and beneficial capability of ER/Studio DA allows users to provide, in literally seconds, clear, easy to navigate, and safe-to-distribute documentation about a database or enterprise data model to those who need to review it.

ABOUT THIS GUIDE

This guide is intended to help you get started using Embarcadero's data modeling and database design solution, ER/Studio DA and its collaborative Repository available in Enterprise Edition.

After completing this guide, you will have the foundation you need to explore the many features and benefits of ER/Studio Data Architect (ER/Studio DA). You will have learned how to do the following:

- Create a new data model.
- Work with logical and physical diagrams.
- Leverage productivity-focused features such as powerful reporting engines.
- Use the Enterprise Edition to collaborate, set versions, and manage model security.
- Use common tasks and commands to make you more productive.

The tutorials are divided into nine sessions. Do them all at once or complete them individually as your time permits.

- [Getting Started with ER/Studio Data Architect](#) on page 4
- [Logical and Physical Modeling](#) on page 6
- [Documenting an Existing Database](#) on page 22

- [Documenting Data Lineage](#) on page 32
- [Diagram Navigation and Aesthetics](#) on page 41
- [Importing and Exporting Metadata](#) on page 48
- [Dimensional Modeling](#) on page 52
- [Automating Tasks](#) on page 57
- [Collaborative Modeling](#) on page 61

You can use this basic tutorial as a road map of product highlights, but also to help you find your own path in exploring ER/Studio Data Architect.

Once you have started, from the Main menu you can click Help to find many additional resources that complement and build on many of the activities shown in this brief guide.

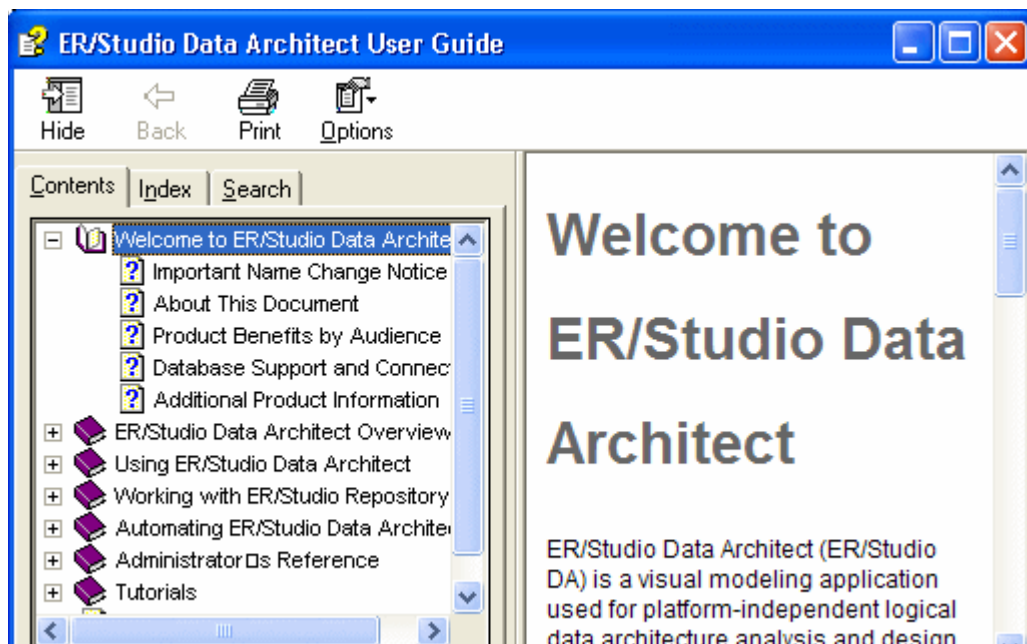

GETTING STARTED WITH ER/STUDIO DATA ARCHITECT

The graphic below names and describes the functionality of some key elements of the ER/Studio Data Architect user interface.

Data Model Explorer displays information about logical and physical models, submodels and nested submodels.

Repository object status icons display real-time user access information.

Sophisticated diagram auto-layout tools provide single-click clean up of diagram objects.

Complex schema objects like functions can be displayed to illustrate dependencies.

Toolbars are dockable anywhere in the ER/Studio application window.

STARTING TO DATA MODEL WITH ER/STUDIO DATA ARCHITECT

- 1 On the Windows **Start > Programs** menu, choose **Embarcadero > ERStudio Data Architect**.
- 2 Choose **File > New > Draw a new data model**.

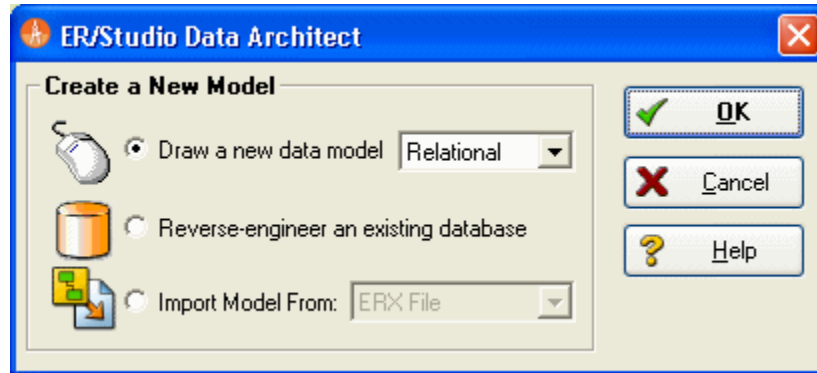

As you can see in the Create a New Model dialog, there are a number of ways to begin modeling with ER/Studio Data Architect:

- Build a new design from the ground up by drawing a new data model.
- Build a data model from an existing database through live reverse engineering.
- Import designs from other modeling products such as Computer Associate's ERwin or SQL files.

TIP: You can select an initial layout style for your model before the SQL import takes place.

- 3 Ensure **Relational** is selected for the new model type and then click **OK**.

After selecting *Draw a new data model* and clicking *OK*, ER/Studio Data Architect will resemble the image below:

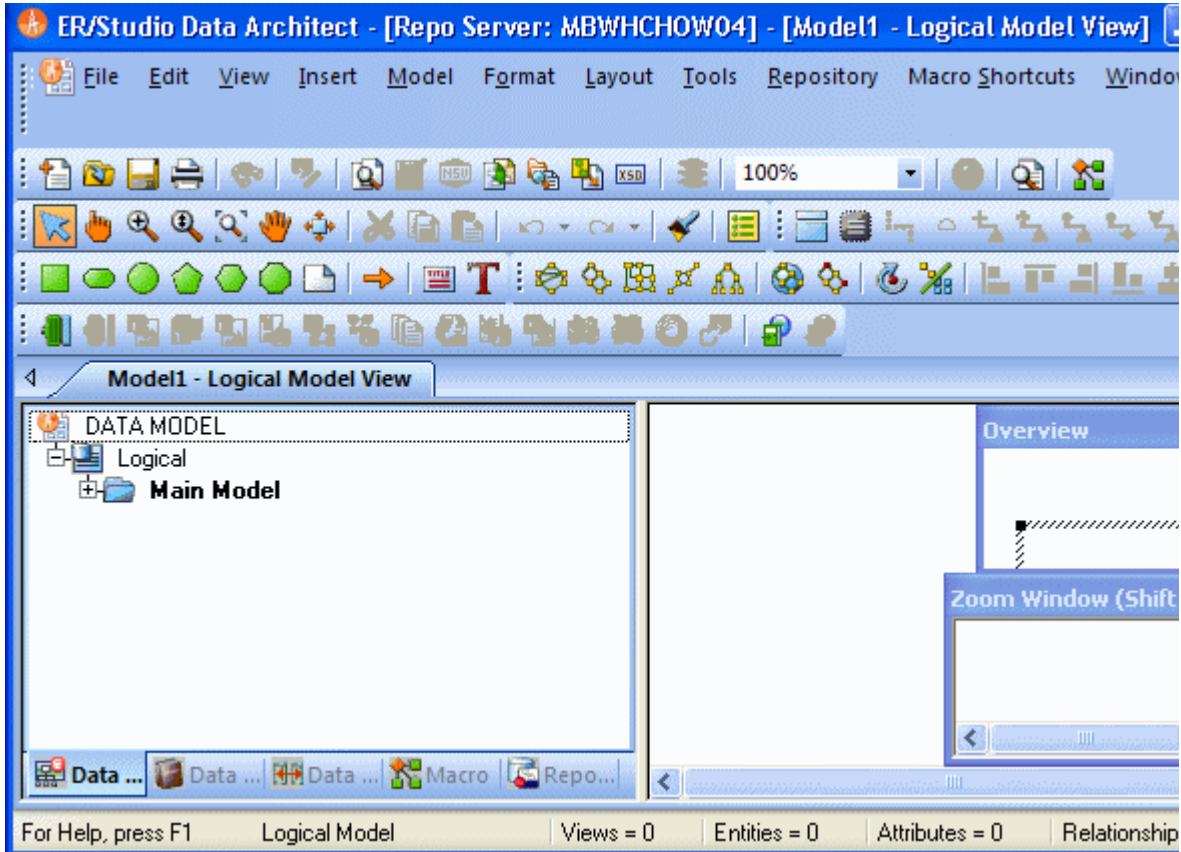

LOGICAL AND PHYSICAL MODELING

ER/Studio Data Architect supports both logical (non-DBMS or technology-specific) modeling and physical (DBMS-specific) modeling. ER/Studio Data Architect is designed to allow organizations the flexibility to analyze and design a business problem or application logically and generate as many different physical interpretations from the logical model as required. Multiple physical models can be generated from the logical model for the same DBMS (for example, Oracle) or other DBMSs (such as Oracle, SQL Server and DB2). Generating logical and physical models will be discussed in detail in the following sessions.

- [Using Data Dictionary Domains to Populate New Entity](#) on page 7
- [Establishing Relationships Between Entities](#) on page 10
- [Creating and Working with Submodels in ER/Studio® Data Architect](#) on page 11
- [Generating Physical Models from a Logical Model](#) on page 14
- [Denormalizing the Physical Model](#) on page 17
- [Finding out How an Entity Maps to the Physical Model](#) on page 20

USING DATA DICTIONARY DOMAINS TO POPULATE NEW ENTITY

As instructed in "[Getting Started with ER/Studio Data Architect](#)" on page 4, you have chosen to draw a new data model to begin a logical model from the ground up. Before we begin to add entities, we will populate ER/Studio Data Architect with some sample domains (Domains are reusable attributes).

- 1 Choose **File > Import Data Dictionary**

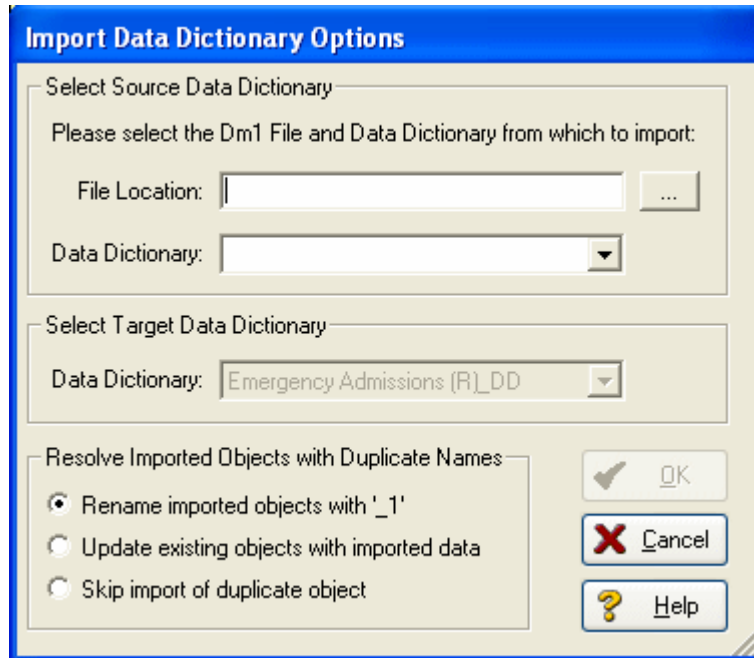

- 2 Next to the **File Location** box, click the **ellipsis** and browse to the **Sample Models** folder, which is located at:

- **For Windows XP:**

C:\Documents and Settings\All Users\Application
Data\Embarcadero\ERStudioDA_X.X\Sample Models

- **For Windows Vista:**

C:\ProgramData\Embarcadero\ERStudioDA_X.X\Sample Models

- 3 Double-click the `Orders.dm1` sample model and then click **OK**.

This model contains a pre-populated, sample data dictionary.

NOTE: Under Resolve Imported Objects with Duplicate Names, you can choose between a couple of options to determine how the dictionary objects are imported. This is important when importing into a diagram that already has dictionary objects in it.

Once opened, you will see that the ER/Studio® DA Data Model Explorer has automatically switched to the Data Dictionary tab to allow immediate drag-and-drop access to domains.

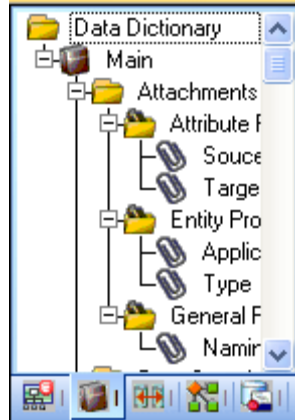

- 4 Now, to add an entity to the Data Model Window, click the **Entity** tool on the **Modeling Toolbar**,

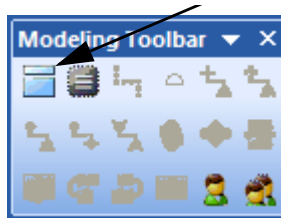

and then click in the Data Model Window to drop the entity.

TIP: The cursor will change to an entity symbol once the Entity tool is clicked, so you can click to drop as many entities on the Data Model Window as you want.

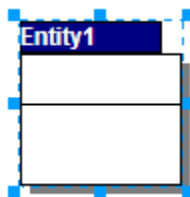

- 5 Right-click to return your mouse to the selection cursor.

- 6 In the entity name field, type `Customer`, replacing the default entity name, `Entity1`.

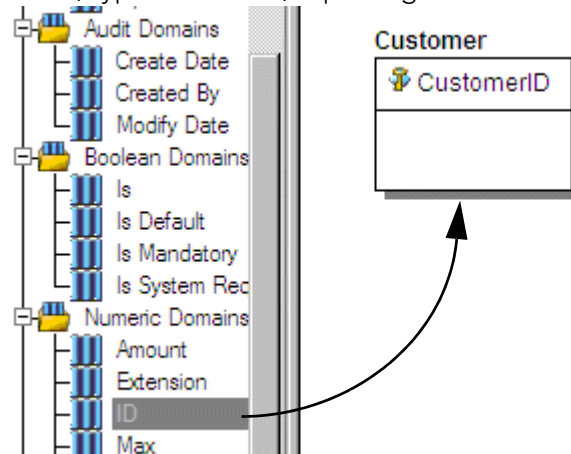

- 7 In the **Domains** folder of the **Data Dictionary** tab, locate the **ID** domain in the **Numeric Domains** folder.
- 8 Click the **ID** domain (do not release your mouse), drag it onto the **Customer** entity, and then release it just below the entity's name, which is the entity's Primary Key field.
- TIP:** You can edit or rename an entity and insert, edit or rename attributes by holding down the Shift key and then clicking the name or attribute. Pressing the Tab key cycles between the entity's name, and primary key and non-primary key fields. After naming the field, press Return to insert a new field.
- TIP:** If you need to zoom in on the entity to read the entity name and attributes, press F8 to view the Zoom Window, then use the scroll bars of the Zoom Window to center the entity on the Data Model Window. Press Shift while rolling the mouse wheel forward to increase the view magnification. You can use the Pan tool to reposition the view to better see the entity.
- 9 In the entity, click **ID**, the name of the attribute we just created from the ID domain, and change its name to `CustomerID`, as seen in the illustration above.
- 10 Repeat the process in [step 7](#) and [step 8](#) to populate the Customer entity with the following domains:
- Name and Phone from the Property Domains folder
 - Address, City, State, Zip Code from the Address Domains folder.
- 11 Drop another entity on the Data Model Window and call it `Order`.
- 12 Drag the ID domain onto the Order entity's Primary Key field, change the ID domain name to `OrderID`.
- 13 Right-click the Order entity and select **Comments**.
- 14 Enter some text in the **Comments** editor, click **Add** and then click **Save**. You can add comments to any database object in the same manner. This can be very useful when you want to provide feedback on a model to other users.

15 Save your data model. We will use it in the next session of this tutorial.

ESTABLISHING RELATIONSHIPS BETWEEN ENTITIES

- 1 On the **Modeling toolbar**, click the **Non-Identifying, Mandatory Relationship** tool.

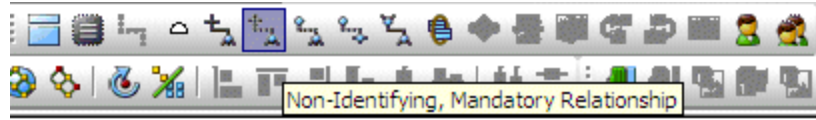

Note: The screen shots of this tutorial were taken using a model where the notation was set to IE (Crow's Feet). Depending upon the notation your model is currently set to, the icons for each relationship will be slightly different.

TIP: You can change the model notation by choosing Model > Model Options, and then choosing another notation option in the Notation area.

- 2 To establish a relationship between Customer and Order, click the parent entity, **Customer** and then click the child entity, **Order**.

NOTE: ER/Studio® Data Architect supports sound design practices by automatically propagating the primary key, from parent to child entities. If there are candidate alternate keys that should also be propagated to the child, in the Relationship Editor you can choose all available parent entity keys in the Parent Key list. Deleting a relationship will remove a non-native propagated attribute. However, if you want to keep the child columns of the relationship or foreign constraint, when you delete the relationship you can check the **Make Foreign Keys Native** option. In this case, if the relationship between Customer and Order is deleted, the CustomerID will be left in the Order entity.

What is a Domain? A Domain is a valuable tool in establishing standard, re-usable Attributes/Columns. They allow data modelers to create a data element once (such as an ID field you require all of your entities to leverage as its primary key) which has the same data type, definition, rule, and constraint no matter where the data element is distributed and bound. Read more about Domains in ER/Studio® Data Architect Help.

CREATING AND WORKING WITH SUBMODELS IN ER/STUDIO® DATA ARCHITECT

Now that you have a general understanding of how to build logical models from the ground up in ER/Studio® Data Architect, it is important to understand how to work with an important navigation feature of ER/Studio® Data Architect, called Submodels. Submodels and nested submodels are designed to break down large, complicated views of a data model in order to focus on a specific area. An important aspect of Submodels to understand is that any changes made in the submodel...*other than layout, color, display settings, notation, etc. which can be unique to the submodel...*will occur automatically in the Main Model view. In other words, change or add an attribute to an object in a Submodel and the change is automatically propagated to its Main Model counterpart.

Close the current sample model, and open a more mature model. Use this exercise to learn more about submodeling.

- 1 Choose **File > Open**.
- 2 Select **Orders.dm1** and then click **Open**.
- 3 To preserve this sample model for future use, choose **File > Save As** and then save the `Orders.dm1` file with a new name.

In this exercise, we will be modifying this model.

- 4 Collapse the folders in the **Data Model** tab of the Data Model Explorer to look like the image below:

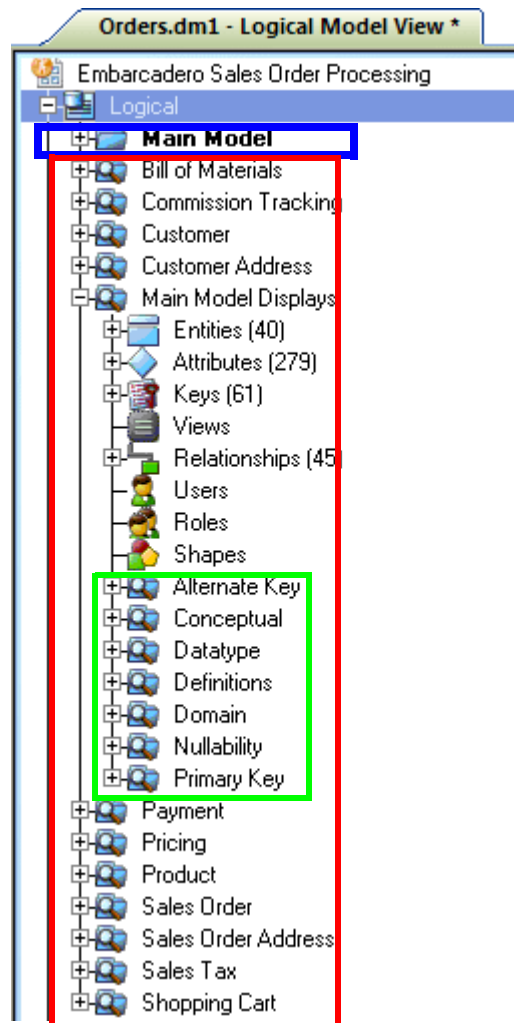

In the `orders.dm1` sample model, there are no physical models. This model includes several submodel folders that help to describe the logical model:

- **Main Model** – This is the entire collection of all logical objects in the `Orders.DM1` file. Note the absence of the magnifying glass on the folder icon which designates it as the main model.
- **Bill of Materials** through **Shopping Cart** – These are submodels, which are smaller collections of entities derived from the Main Model that help to describe specific areas of the Main Model free from other entities.
- **Alternate Key** through **Primary Key** – These are nested submodels, which can go 'n' levels deep and are literally submodels of submodels.

Feel free to explore. Click the plus sign (+) to expand these folders.

Let's create a submodel with all the objects related to the `orders.dm1` Address components.

- To make a new submodel, navigate to **Logical Main** model and with the **CTRL** key depressed, click the objects in the Data Model Explorer. as seen in the image below.

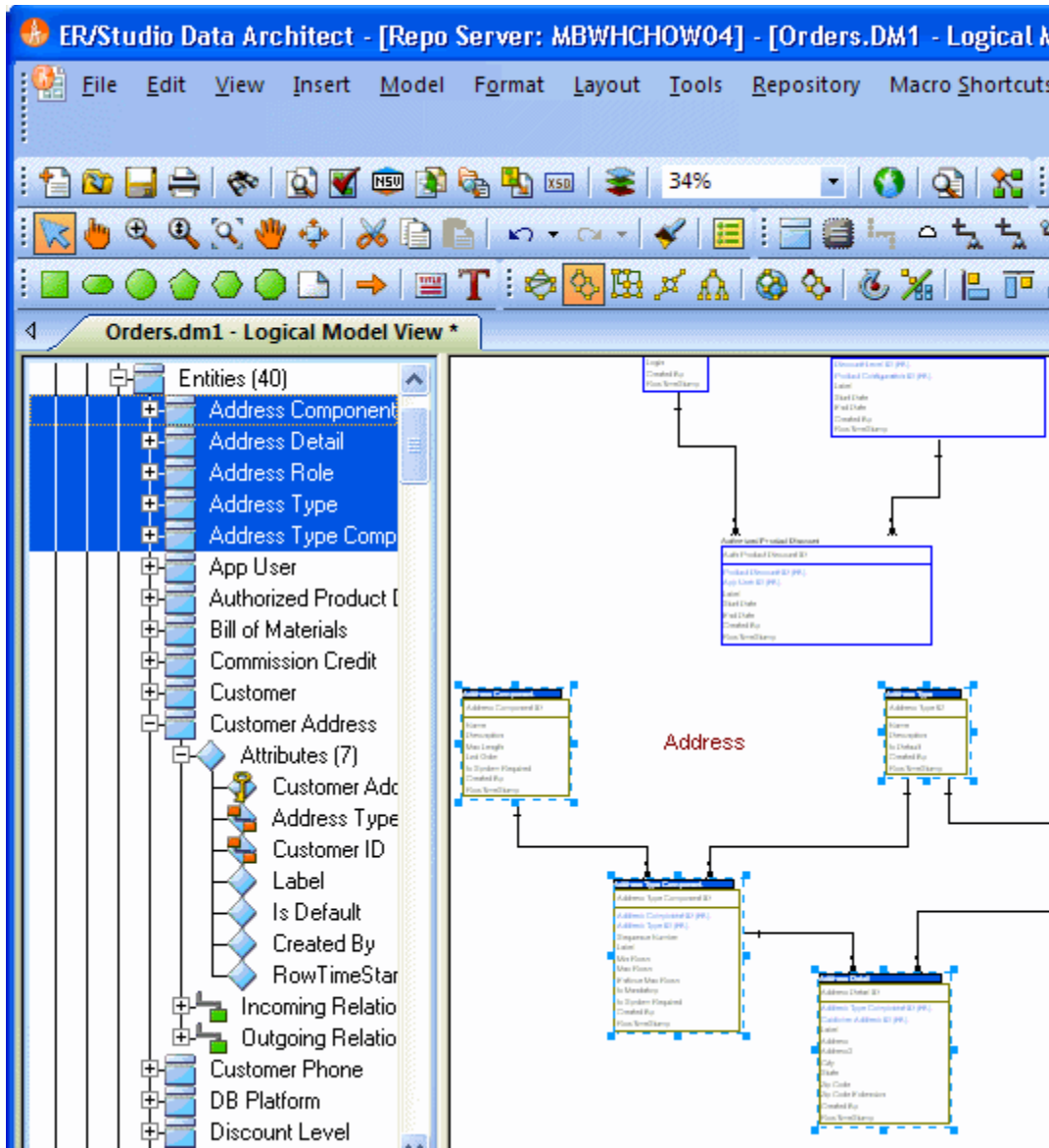

NOTE: Any objects selected in the Data Model Explorer will also be selected on the Data Model Window as well (also seen here). You can also select entities by lassoing them on the Data Model Window. With the entities selected, choose Model > Create Submodel.

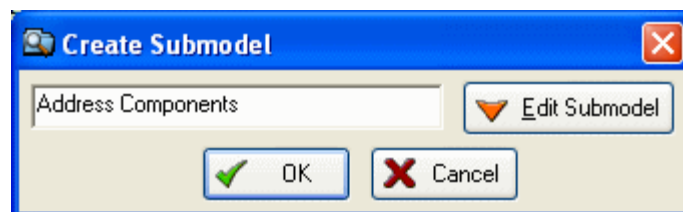

- 6 Below **Create Submodel**, enter `Address Components` as the name for the submodel.
- 7 Click **OK**.

ER/Studio® Data Architect creates the Address Components submodel.

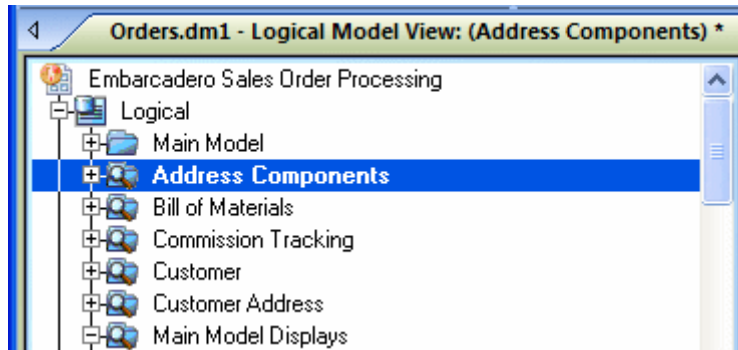

What do the results look like and how do I navigate to the submodel? Once created, you will see the new submodel listed in the Data Model Explorer, denoted as a submodel by the magnifying glass over its folder, as in the case with Bill of Materials and the other submodels.

GENERATING PHYSICAL MODELS FROM A LOGICAL MODEL

ER/Studio® Data Architect can generate as many physical models from a single logical model as desired. There are many ways to leverage multiple physical models in ER/Studio® Data Architect to help the design process. Examples of how multiple physical models are used are:

- Managing change in an existing application: Maintain independent development, test, and production physical model diagrams that represent specific databases.
- Migrating database applications: Use ER/Studio® Data Architect as an analysis and design hub for migrating database applications. Manage a physical model of the legacy source database application in addition to its new target physical model, which can be for an entirely new DBMS than originally maintained in the legacy database.

Let's generate a new physical model from a logical model in order to build a database. we will use the `orders.DM1` sample model.

- 1 Open your version of the `orders.DM1` sample model.

TIP: Use the steps shown in the last session to do so.

- 2 Select the **Main Model** and then choose **Model > Generate Physical Model**.

ER/Studio® Data Architect invokes a step-by-step wizard to walk you through the process of generating a DBMS-specific physical model.

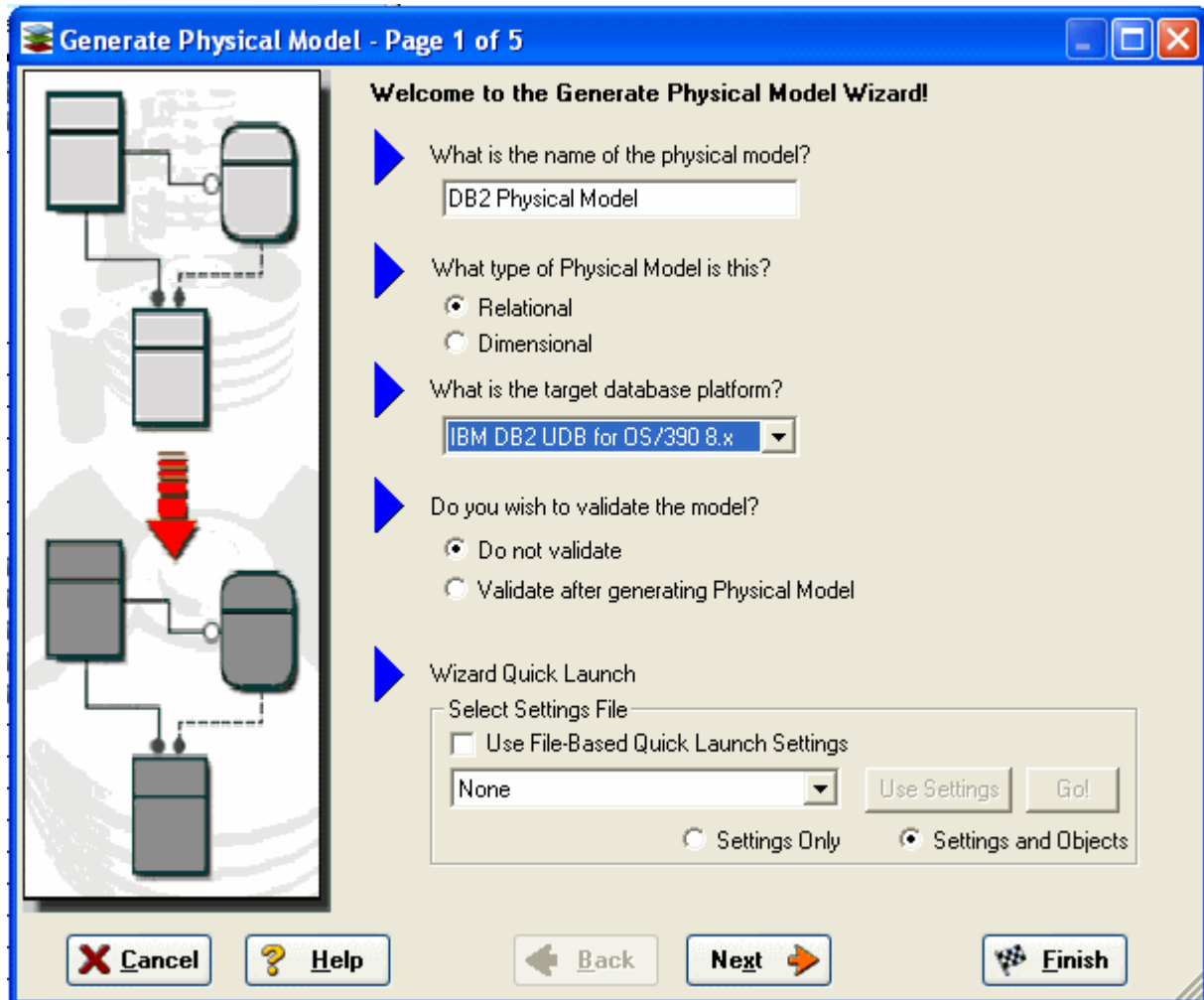

- 3 Name the new physical model, `DB2 Physical Model` and then select **DB2 UDB for OS/390 8.x** as the target DBMS to generate.
- 4 Continue through the **Generate Physical Model Wizard**, which prompts very clear and concise questions about how you want your physical model to be generated.

NOTE: The wizard prompts you to customize items such as individual object selection, index assignment, default storage parameters, resolution of many-to-many relationships that may be in the logical model, and naming conventions. A DBMS-specific validation check is also provided in this wizard.

TIP: The Quick Launch can store common settings so that an operation can be reused on this model or on any other models. You can reuse the settings on another model by choosing the Use File-Based Quick Launch Setting option when saving the Quick Launch information on the last page of the wizard.

- To generate the new **Physical** Model, on the last page of the wizard, click **Finish**.

Now that a physical model has been generated from the logical model, feel free to navigate to specific objects via the Data Model Explorer, such as the CUSTMR table selected here. Double-click and view the physical details of the object such as DDL, Indexes, Partitions, and Storage.

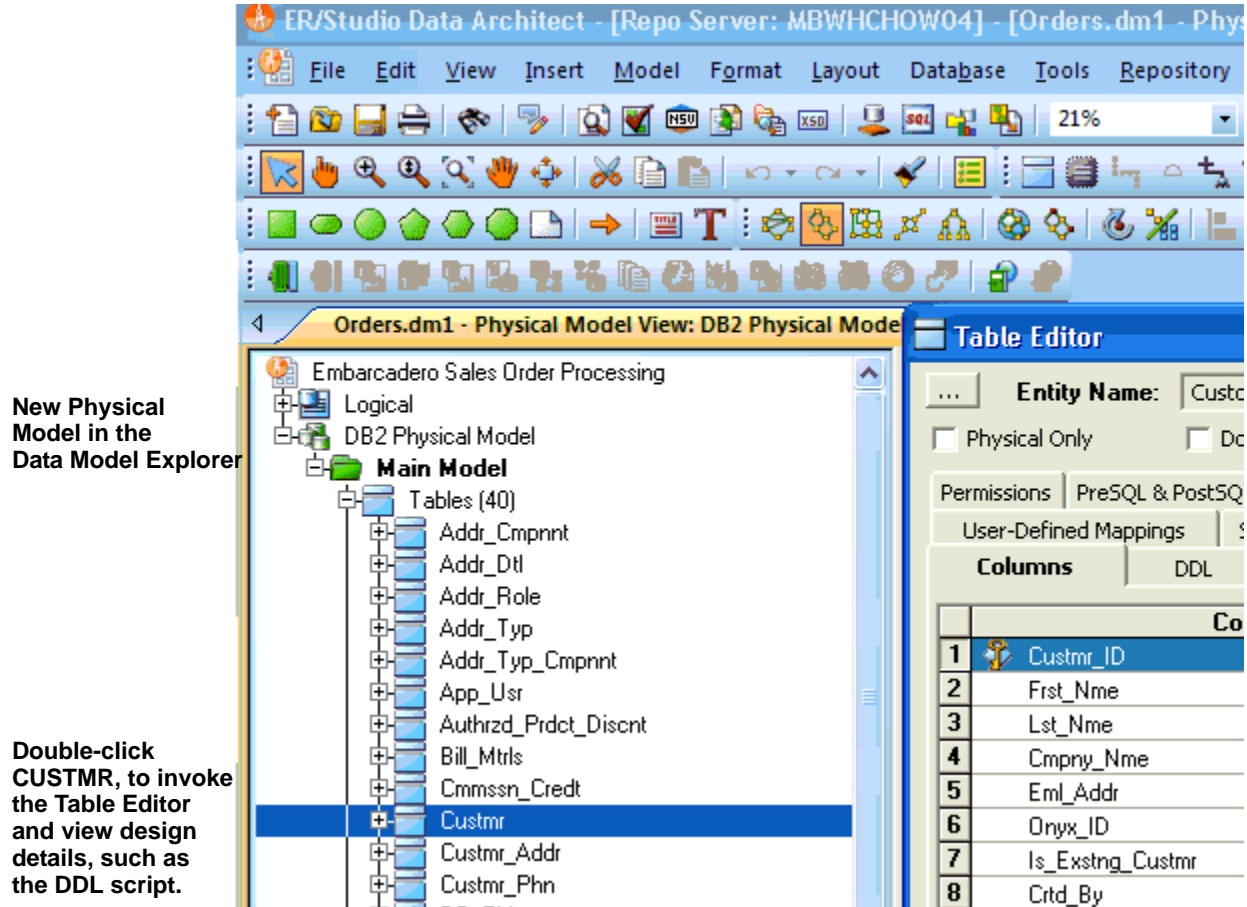

DENORMALIZING THE PHYSICAL MODEL

ER/Studio Data Architect comes equipped with denormalization wizards to help you optimize the physical design once the physical model is generated. The wizards help automate the process and keep the ties between the physical tables and the logical entities.

The active, denormalization wizards available depend on which tables are selected in the physical model when you select Denormalization Mapping. For example, if two tables that are related to each other are selected, the valid operations would be Rollups or Rolldowns.

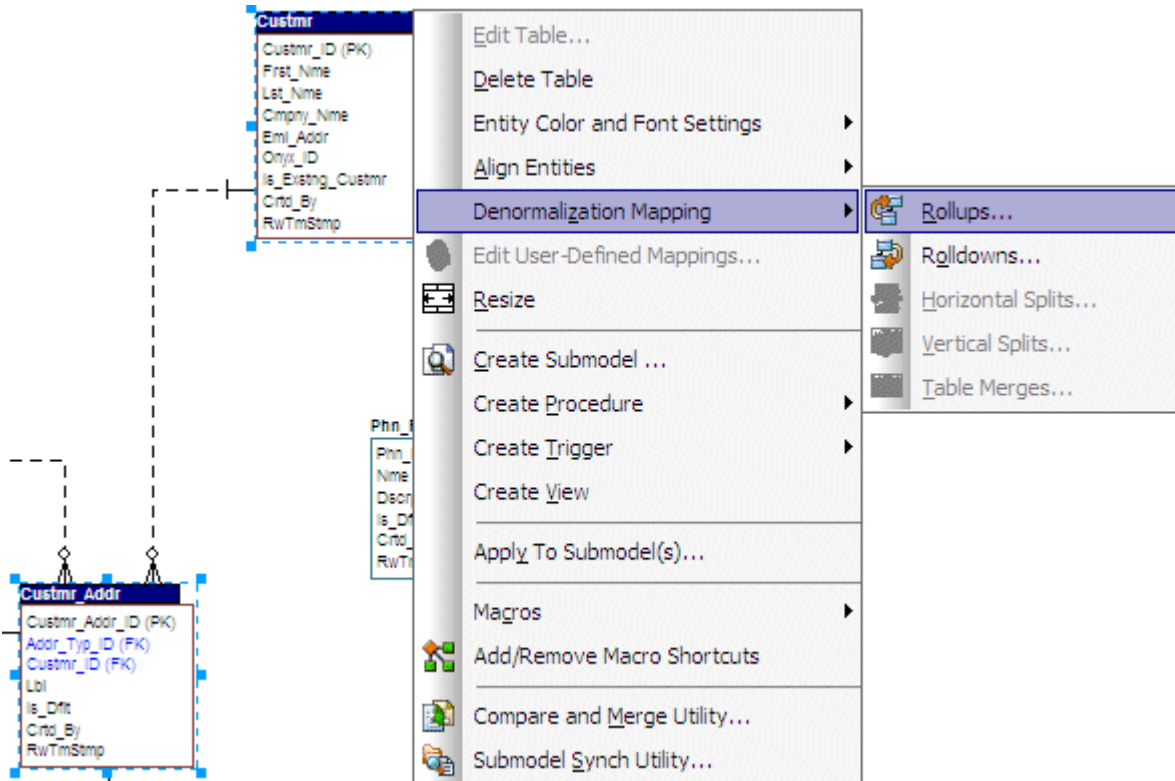

When only one table is selected, the option to split the tables becomes available. The Table Merge option is available when two unrelated tables are selected.

Let's walk through an example of a denormalization operation using the generated physical model in a previous session of this tutorial. We may want to reduce the overhead on the `Custmr` table by splitting it into two physical tables, `Custmr_East` and `Custmr_West`. Splitting the table can reduce the query time and provide opportunities to store the tables at different locations which could further reduce lookup time.

Before the operation, the `Custmr` table should look like:

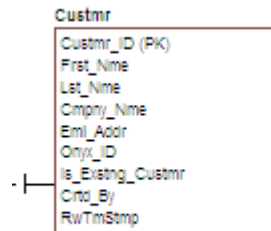

- 1 Open the `orders1.dml` model you modified and saved in the last session.
- 2 In the Data Model Explorer, right-click the `Custmr` table.

3 Choose **Denormalization Mapping > Horizontal Splits**.

Notice that since only Custmr is selected, the only possible mappings are vertical and horizontal splits.

The Horizontal Table Split Wizard launches.

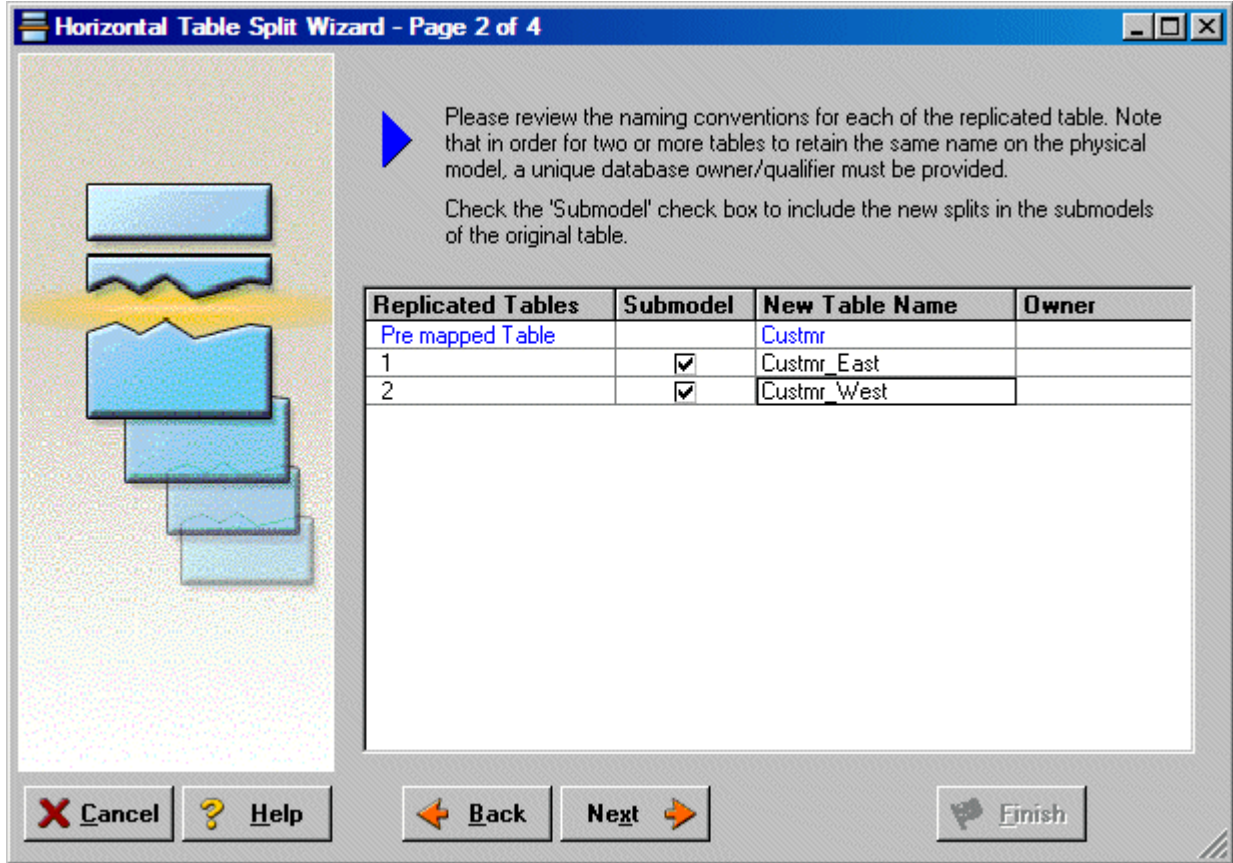

4 On Page 1, type 2 for the number of splits.

5 On Page 2, rename splits1 and 2 to Custmr_East and Custmr_West respectively.

6 On Page 3, click **Next**.

We will keep all the relationships.

7 On Page 4, type a name and definition for the denormalization operation, select **Reflect changes to original tables**, and then click **Finish**.

Finished! After the split the Custmr table will be two physical tables that look like this:

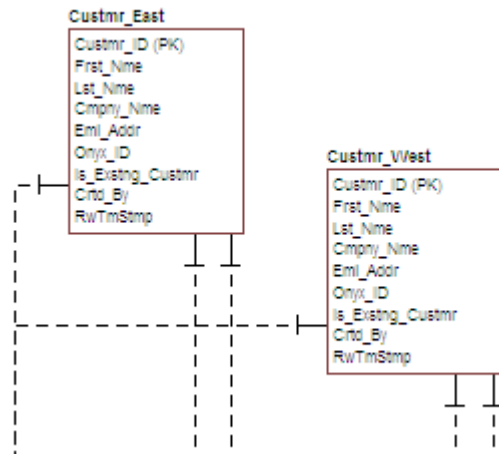

The two tables are identical except for the name.

You can selectively choose which attributes are included in the resultant tables by using a vertical split.

The denormalization mapping is stored in the data model tree underneath the submodels. You can use this to undo the operation or see the history of what happened. ER/Studio® Data Architect tracks the before and after states of these operations. This comes in handy in the next section where we discuss the **Where Used** analysis that can be performed between the logical and physical models.

FINDING OUT HOW AN ENTITY MAPS TO THE PHYSICAL MODEL

Now that we have performed a denormalization operation, the logical entity, Customer, essentially has become two physical tables, **Custmr_East** and **Custmr_West**. The ties between the logical and physical models are not lost. ER/Studio DA allows you to see what Customer in the logical model maps to in the DB2 physical model.

Let's take a look at the Customer entity in the logical model.

- 1 In the Data Model Explorer, navigate back to the **Customer** entity in the Logical model.
- 2 To start the Entity Editor, double-click the **Customer** entity.

- 3 Click the **Where Used** tab.

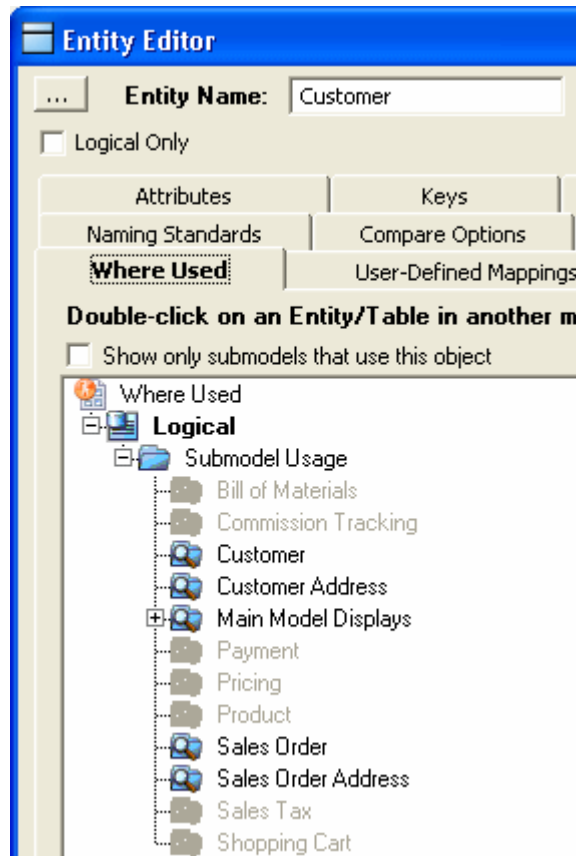

Once the tree is expanded, you can see the lineage of what has happened to the object. Notice that `Custmr_East` and `Custmr_West` are listed as physical implementations of the `Customer` entity. The denormalization mapping object from the data model explorer tree is visible to see how the end result was achieved.

The Where Used tab also displays the submodel usage of a particular entity within the logical or physical model. This allows you to see which business areas the entity belongs to.

NOTE: Where Used information is also available for attributes and columns.

Conclusion

In this session, you have seen how incredibly quick and easy it is to:

- Build a logical data model from scratch.
- Create a new submodel view to understand how to model on specific parts of a larger Main Model.
- Generate a physical model from a logical database in preparation for building a new database.
- Denormalize objects in the physical model.
- View the mappings between the logical and physical models using the Where Used tabs.

For more information, refer to the ER/Studio Help and then review the topics “Developing the Logical Model,” “Developing the Physical Model,” “Synchronizing Physical and Logical Models,” and “Generating a Script File or Database.”

DOCUMENTING AN EXISTING DATABASE

One of ER/Studio® Data Architect’s most powerful applications is that of a documentation generator to communicate complex databases and associated metadata to the Enterprise. ER/Studio® Data Architect is equipped with extensive report generation capabilities:

- **HTML Report Generation:** Instantaneous generation of an HTML-based Web site designed to provide simple navigability through data models and model metadata using standard browsers such as Microsoft’s Internet Explorer or Netscape Navigator.
- **RTF Report Generation:** Instantaneous documentation generation compatible with applications like Microsoft Word.

In the exercise below, we will reverse-engineer an existing database and generate an HTML report for distribution and navigation to those who depend upon the information about the data model, but who may not be permitted to connect to the database for security or organizational reasons.

GENERATING AN HTML INTRANET DICTIONARY REPORT

PRE-REQUISITE: This exercise assumes that you can connect to an existing database in order to document it. Please refer to “Reverse-Engineering an Existing Database” in ER/Studio® Data Architect Help for explicit setup details if needed. If you cannot connect to an existing database, you can still generate documentation from the installed sample models. Skip steps [step 1](#) through [step 7](#) below which relate to in reverse-engineering and begin at [step 8](#) after opening a sample model included with ER/Studio® Data Architect.

- 1 Choose **File > New**.

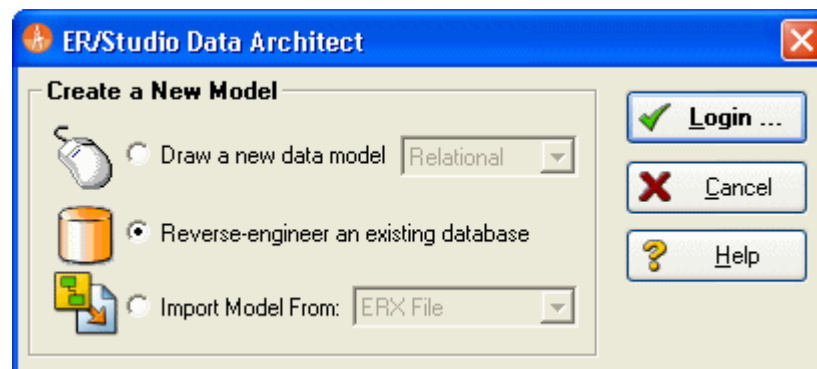

- 2 Select **Reverse-engineer an existing database**.

- 3 Click **Login**.

You can reverse engineer the database from either an ODBC datasource or via Native RDBMS client connectivity. In this example, Native Connectivity to Microsoft SQL Server will be demonstrated.

- 4 Type the relevant connectivity information such as the data source name, and user name and password and then click **Next**.

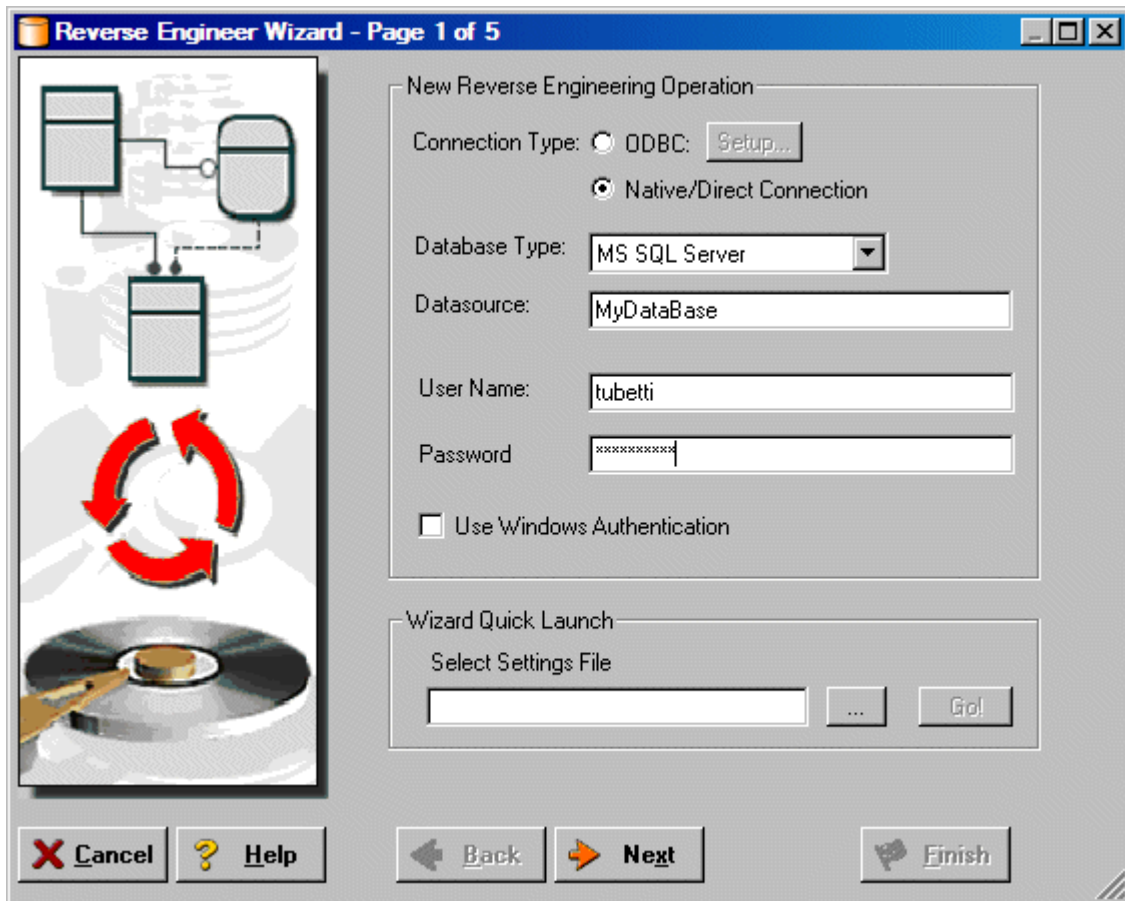

- 5 Walk through the Reverse Engineer Wizard selecting the objects, options, and layout preferences for the model.

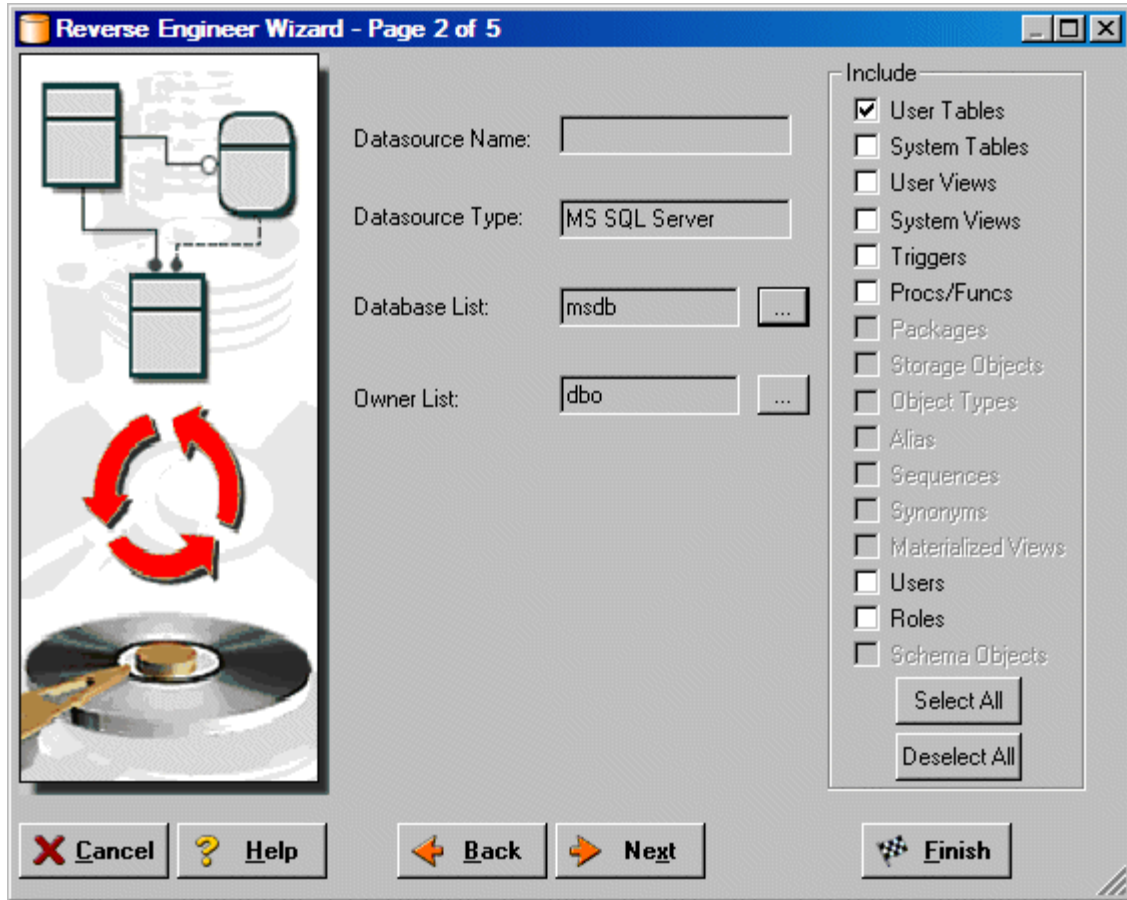

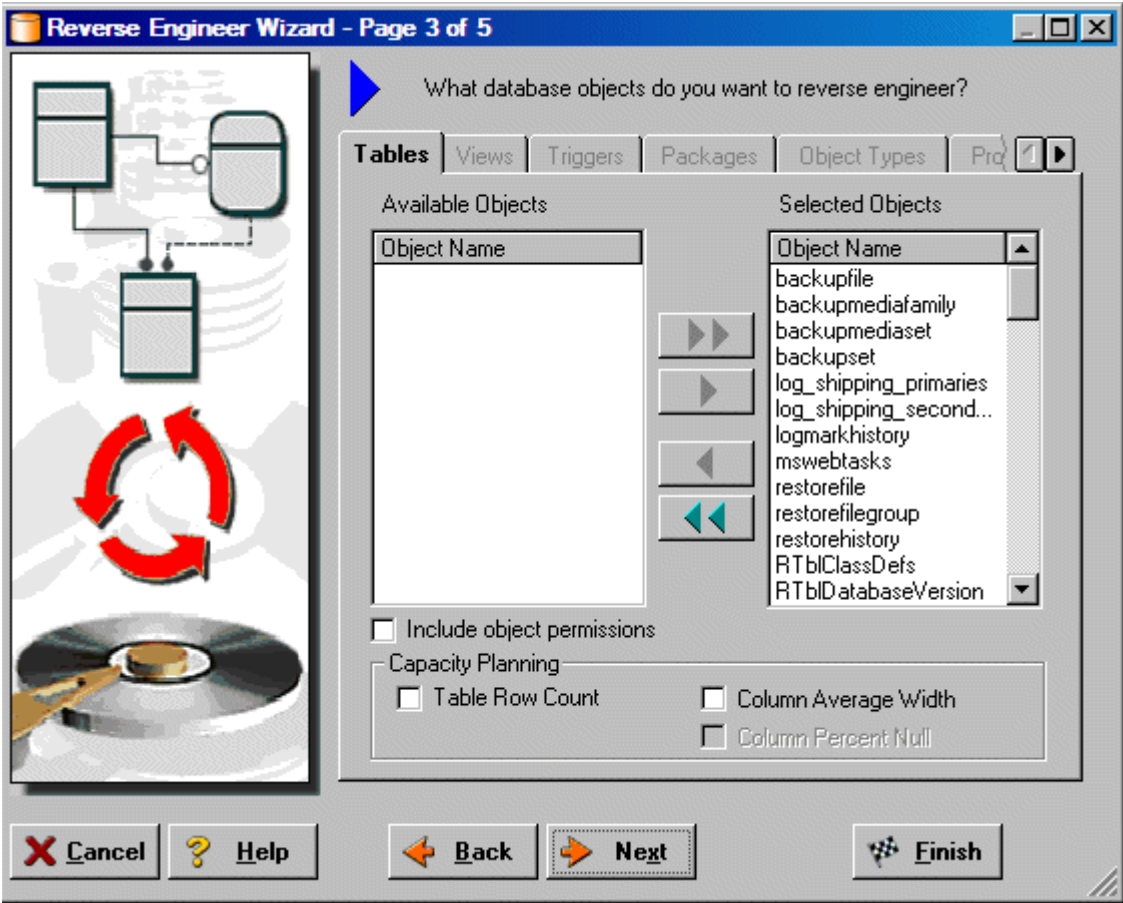

- 6 Continue through the wizard to select layout styles and other preferences.

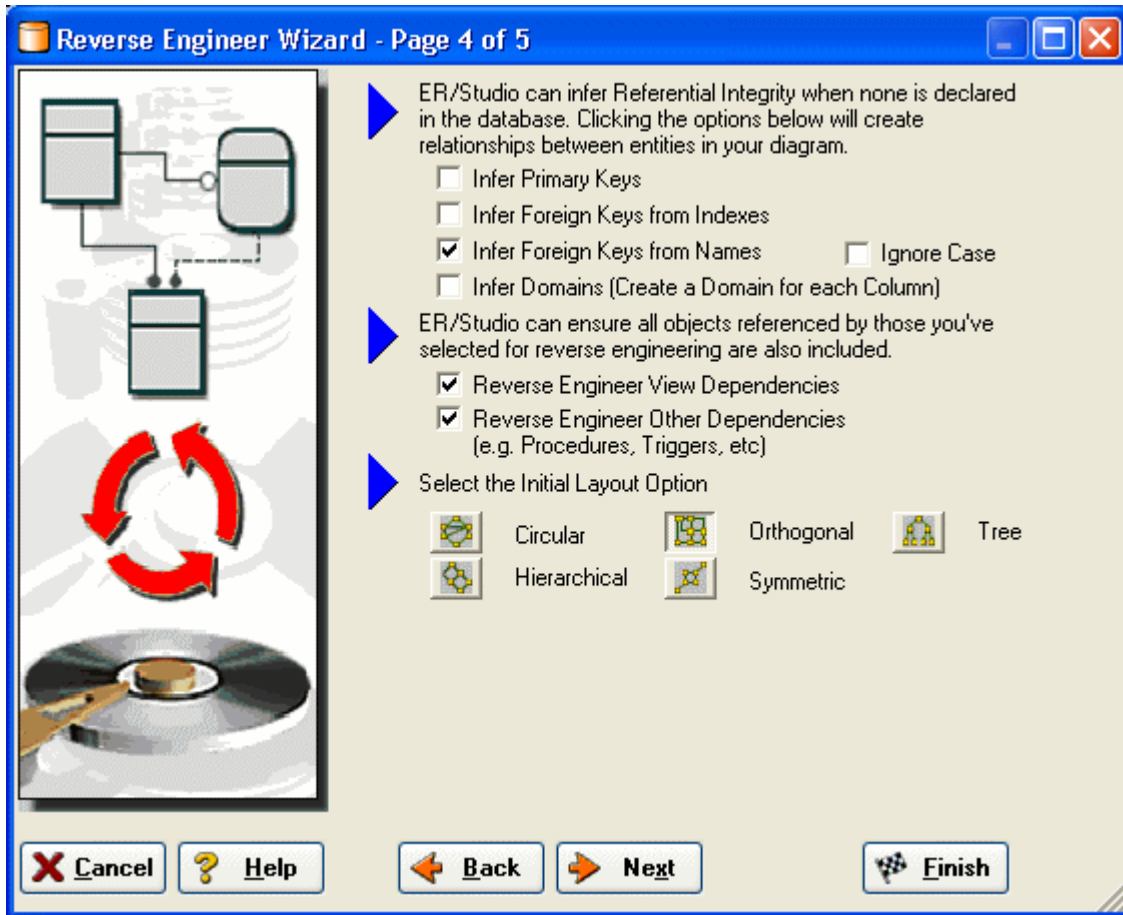

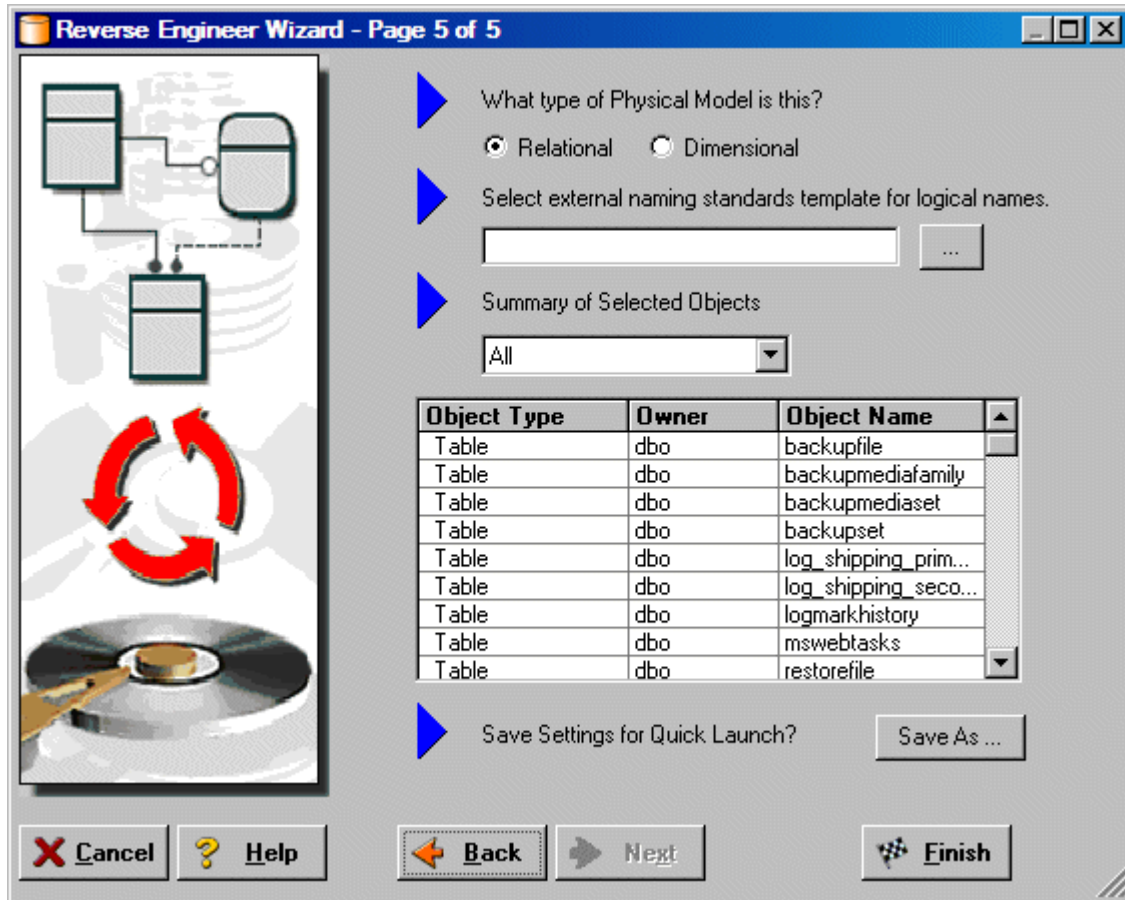

- 7 Click **Finish** and ER/Studio® Data Architect reverse engineers your database!

Once reverse engineering of your database is complete, we will generate a complete HTML report of the database for others in your organization to review.

- 8 In the Data Model Explorer, select the **Physical Main Model**.

9 Choose **Tools > Generate Reports**.

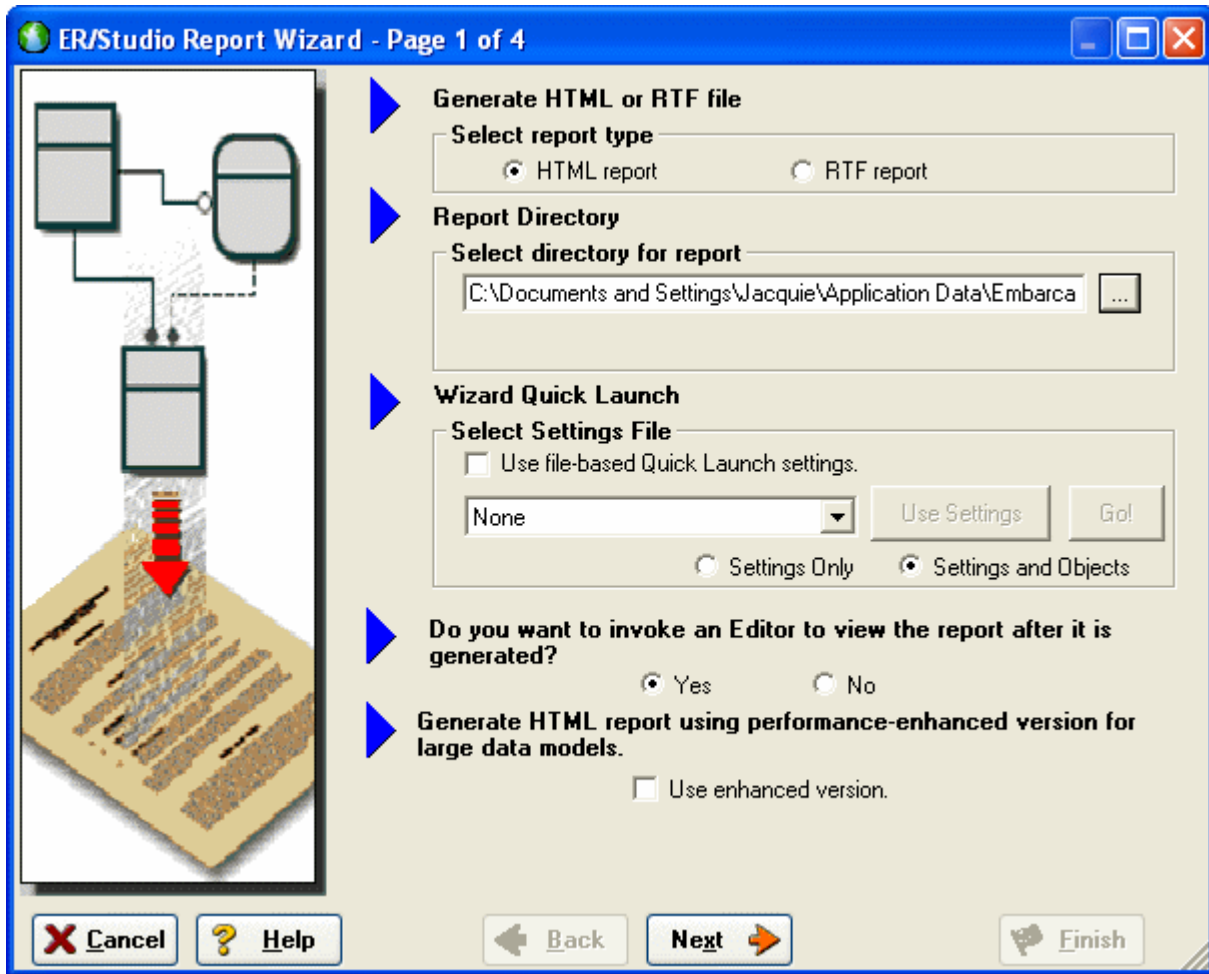

10 On the first page of the wizard, for the report type, select **HTML**.

- 11 On page 2, click **Select All** in both areas of the **Diagram** tab.

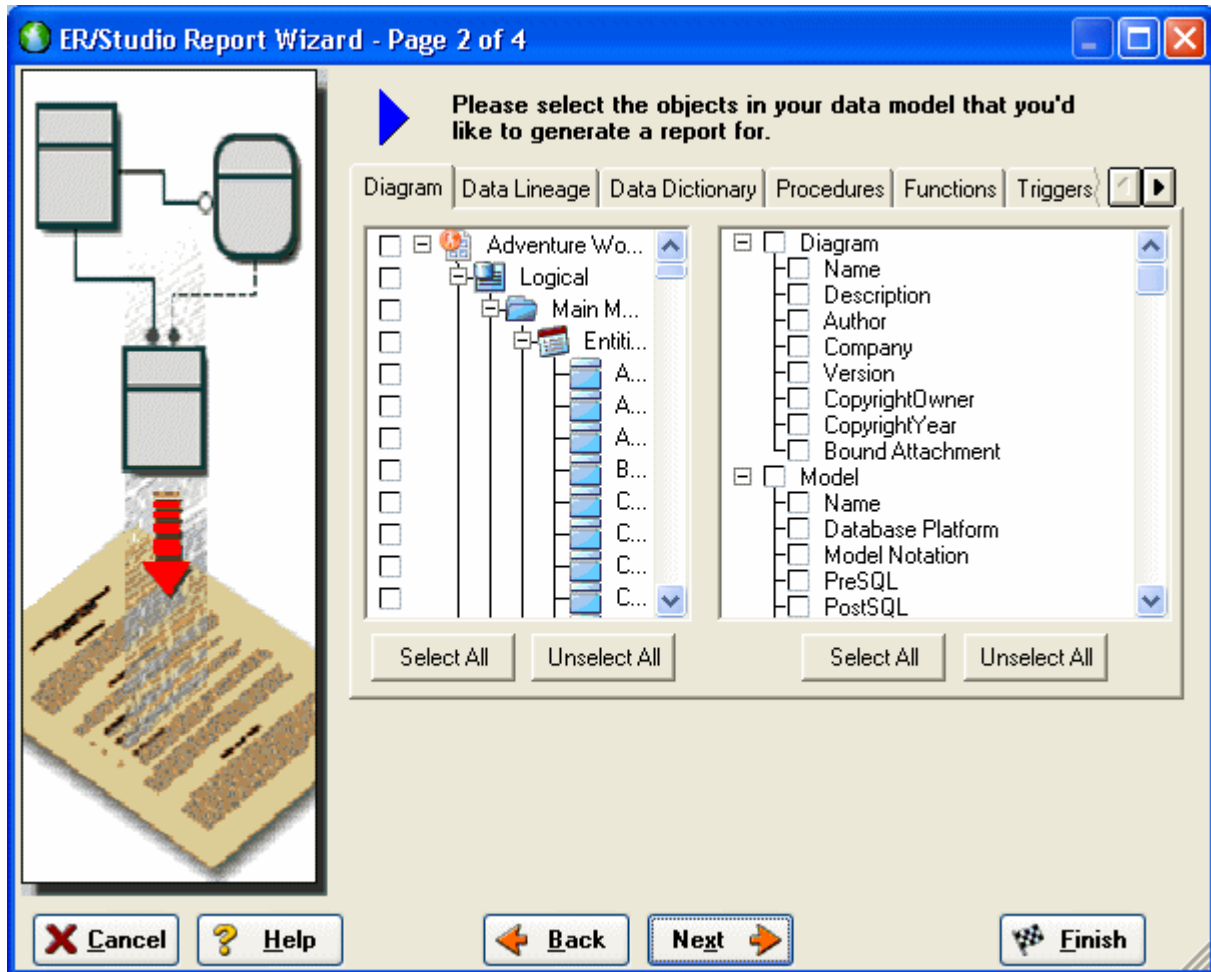

- 12 Click **Select All** in both areas of the **Data Dictionary** and the **Procedures** tabs, and then click **Next**.

NOTE: The tabs available on page 2 depend on what objects are supported by the database platform of the selected model. Some databases support more database objects than Microsoft SQL Server 2005, such as Oracle11g and IBM DB2 LUW 9.x for which there are also tabs on this page for procedures, functions, triggers, packages, and tablespaces. If the model was previously denormalized, a Denormalization Mappings tab would also appear.

- 13 On page 3, in the **Submodel Image Options** area, click **Select All**.

TIP: In the Logo and Link Options, you can choose to replace the ER/Studio® Data Architect default Embarcadero Technologies logo in favor of your own corporate logo (and Hyperlink).

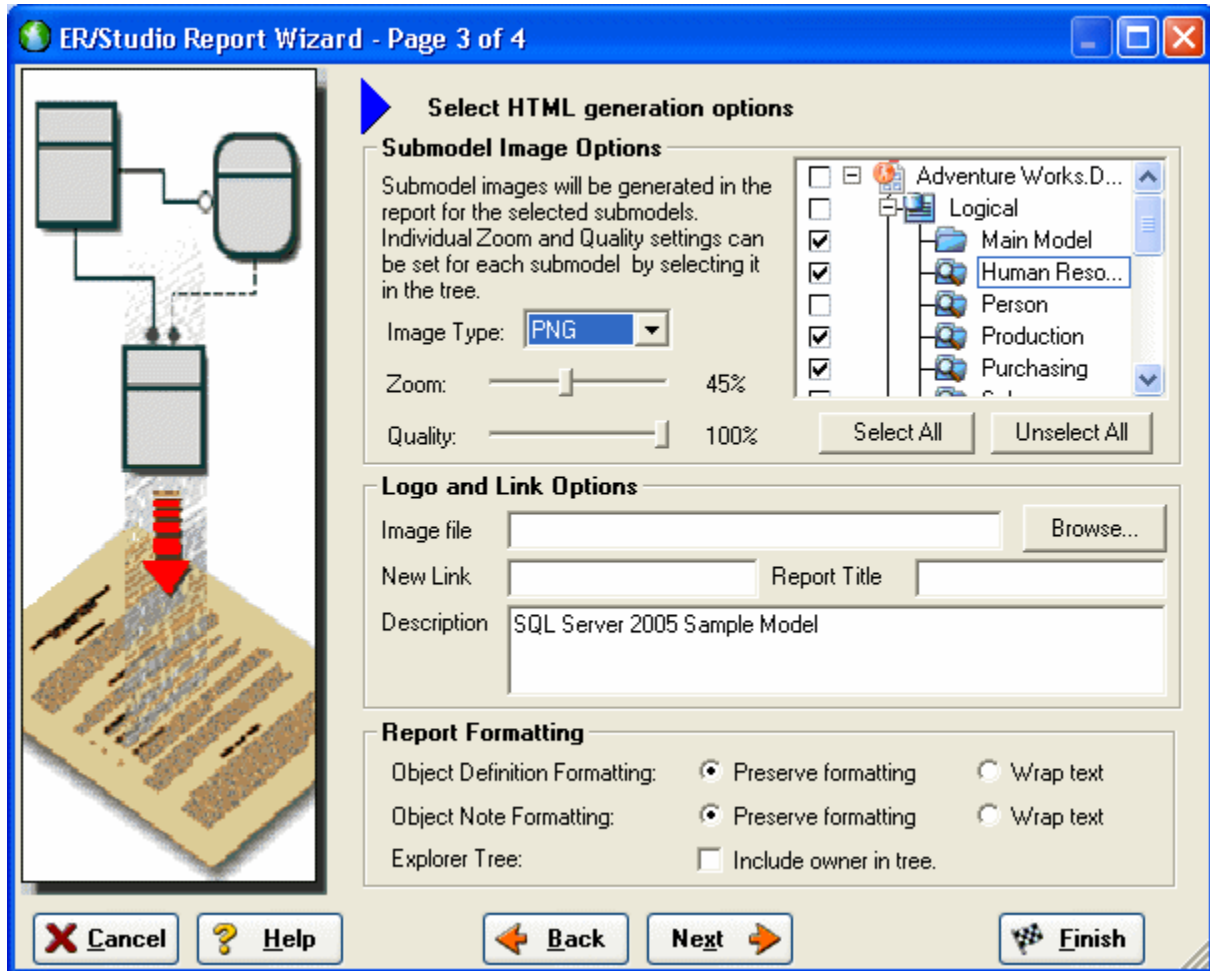

Because HTML formatting can be included in object definitions, you can also choose to preserve the formatting specified on the Definitions tab of the various object editors.

- 14 Click **Next** to advance to Page 4 of 4, and then click **Finish**.

ER/Studio® Data Architect then begins the report publication process and launches the default browser so you can review the report.

15 Finished!

Start navigating the report via your browser. Navigation will perform exactly as it does when you are using ER/Studio® Data Architect! Expand the tree to find Model Image and click on it (see below). You will see a read-only version of your data model (as seen below). Use the Explorer to navigate to any metadata you want or select the entities and relationships in the model image to jump to their information.

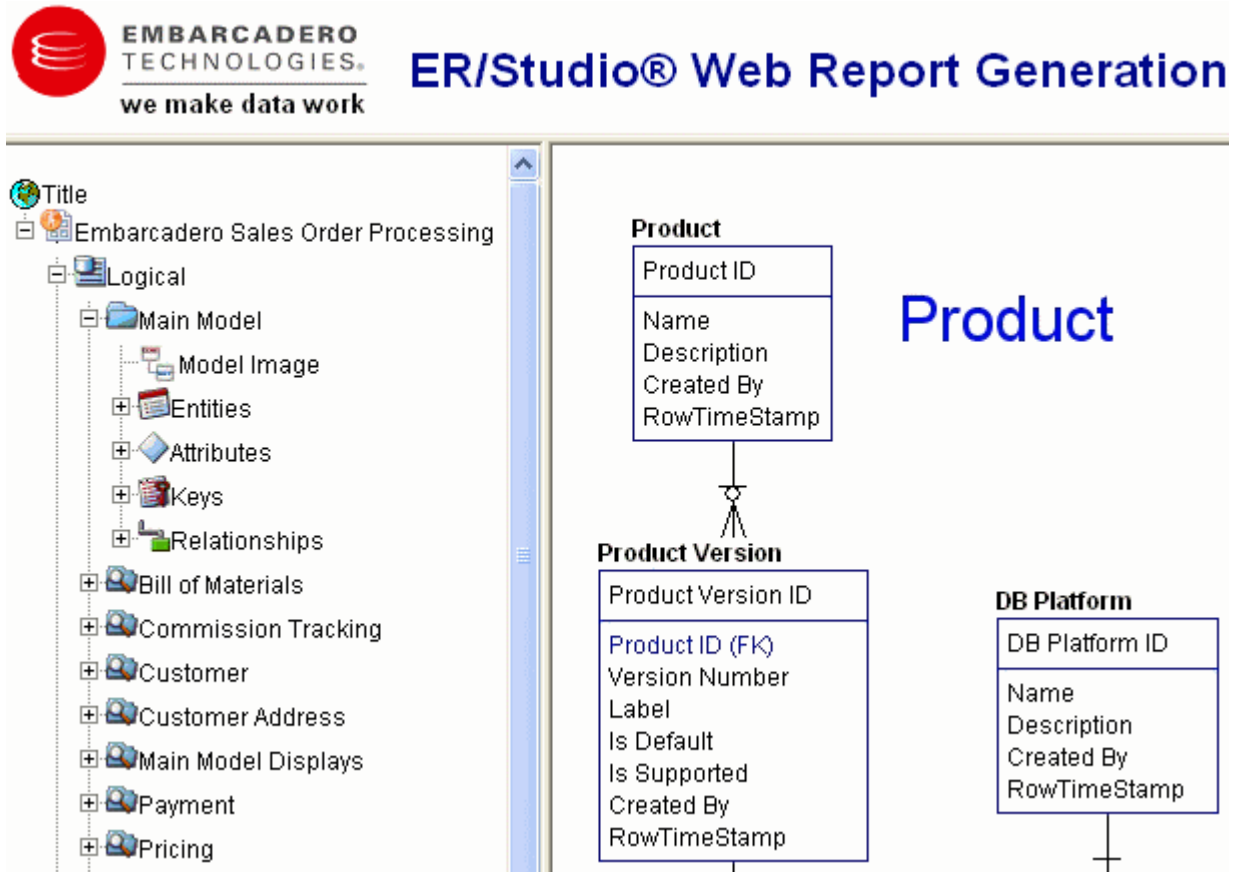

Conclusion

In this session, you learned how to:

- Connect to and reverse-engineer an existing database with ER/Studio® Data Architect.
- Document a database in seconds by using ER/Studio® Data Architect's automatic HTML documentation publication facility.

For more information on Reporting, refer to ER/Studio's Help and review the "Generating RTF and HTML Model Reports" section.

DOCUMENTING DATA LINEAGE

The Data Lineage feature of ER/Studio® Data Architect enables you to document the movement of data from point A to point B (and any intermediate steps in between). This movement is sometimes referred to as Extraction, Transformation and Load (ETL). Points A and B can be anything from flat files, high-end databases such as Oracle and DB2, XML, Access databases, and Excel worksheets. This is sometimes referred to as source and target mapping. A model produced in ERStudio can represent any point along the way. Data Architects need the ability to specify the *source* or *target* of data down to the column-level. Along with the metadata that defines the source and target mapping are rules for how the data is manipulated along the way.

This section will help you document the data lineage of your systems. It is comprised of the following tasks which correspond to the general ETL workflow:

- [Creating a Data Flow](#) on page 33
- [Creating a Data Movement Rule](#) on page 34
- [Defining External Source and Target Systems](#) on page 36
- [Creating a Data Lineage and Transformation Visualization](#) on page 38

CREATING A DATA FLOW

The Data Flow organizes and encapsulates one data transformation and the source tables and columns used in the transformation to produce the target data. Multi-tiered mappings are possible and there can be multiple transformations involving different columns between two tables as illustrated below.

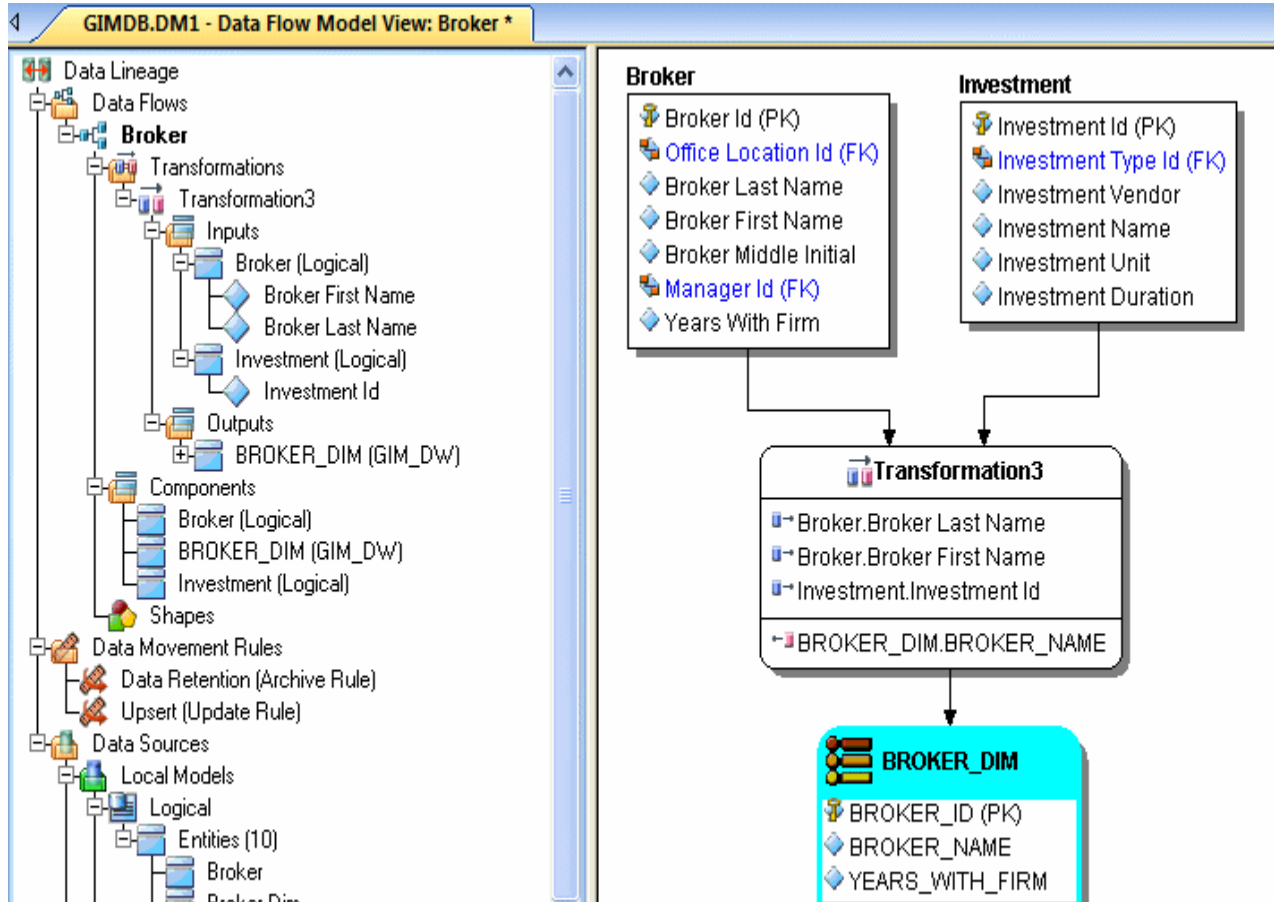

Create a Data Lineage Data Flow

- 1 Choose **File > Open** and select the GIMB.DM1 diagram in the sample Models directory.
- 2 Click the **Data Lineage** tab at the bottom of the application window.

You are prompted to create a **Data Lineage Data Flow**.

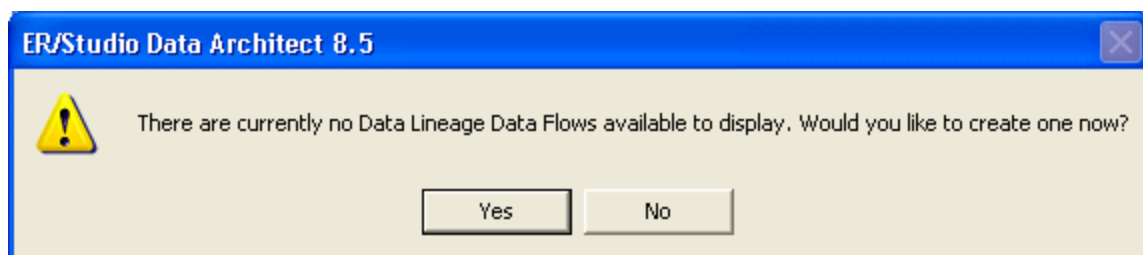

- 3 Click **Yes**.

*If this is not the first time you click the Data Lineage tab after opening a diagram, from the Data Lineage explorer, right-click the **Data Flows** node and then click **Create Data Flow**.*

- 4 Enter a **Data Lineage Data Flow** name and then click **OK**.

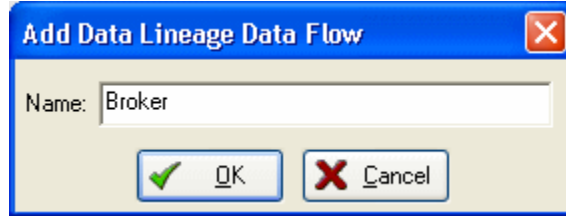

NOTE: The name that appears in the diagram title tab at the top of the application window is appended with : data flow name, when you click a task in the Data Lineage explorer, such as GIMDB.DM1 - Data Flow Model View: Broker*.

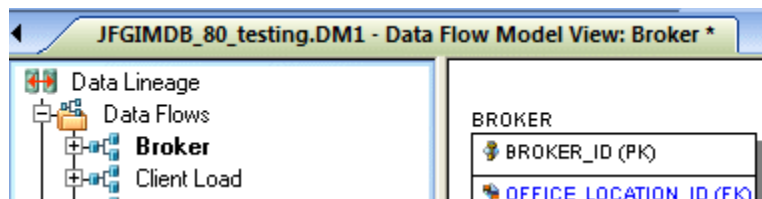

The Data Flow has been created.

CREATING A DATA MOVEMENT RULE

Data Movement rules describe how source and target tables and entities are related. You can relate source data to one or more tables and entities in the same model, the active diagram, or to tables imported from external systems. The rules defined here are used at the table level on the Data Lineage tab of the entity and table editors.

Create a data movement rule

- 1 On the **Data Lineage** tab, right-click **Data Movement Rules** and choose **New Data Movement Rule**.

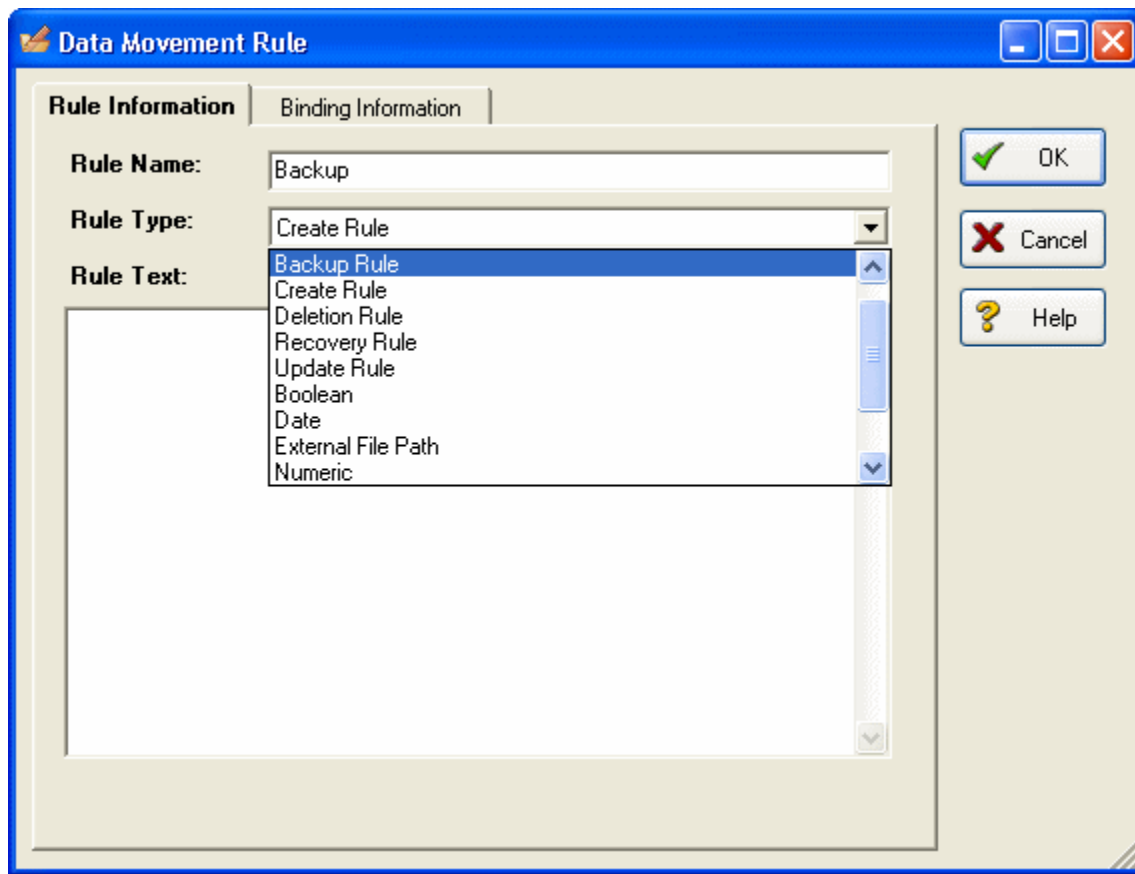

- 2 Complete the **Data Movement Rule** editor as required and then click **OK** to exit the editor.

TIP: Once created, you can edit the Data Movement rule by double-clicking it to launch the Data Movement Rule editor.

The following describes options that require additional explanation:

Rule Information tab

- **Rule Name:** Enter a name that indicates the operation and objects acted on, depending on the specifics of your binding definition.
- **Rule Type:** Select a generic movement rule type that best describes the data movement.
- **Rule Text:** Document your data movement plan here, perhaps adding instructions or contingency plans.

Binding Information tab

Select the object classes and/or specific objects to which you want to bind this attachment. You can override this setting using the Data Lineage tab of the entity or table editor.

DEFINING EXTERNAL SOURCE AND TARGET SYSTEMS

Data sources can originate from models in the active diagram (local models) or from external sources that are either imported into the active diagram or created on the Data Lineage tab. A data source can be imported from *.dm1 files, *.at1 files, database or from SQL files, flat files, and other common application files. The following describes how to import metadata from an external source.

NOTE: Source data imported through the Data Lineage tab only includes information such as table and column name, datatype, nullability, primary key, and column definitions. To obtain more details, reverse engineer the database or import it into ER/Studio® Data Architect using the Metadata Wizard.

Import external source or target data

- 1 From the **Data Lineage** tab, expand the **Data Sources** node.
- 2 Right-click **Other Sources** and choose **Import New Source**.

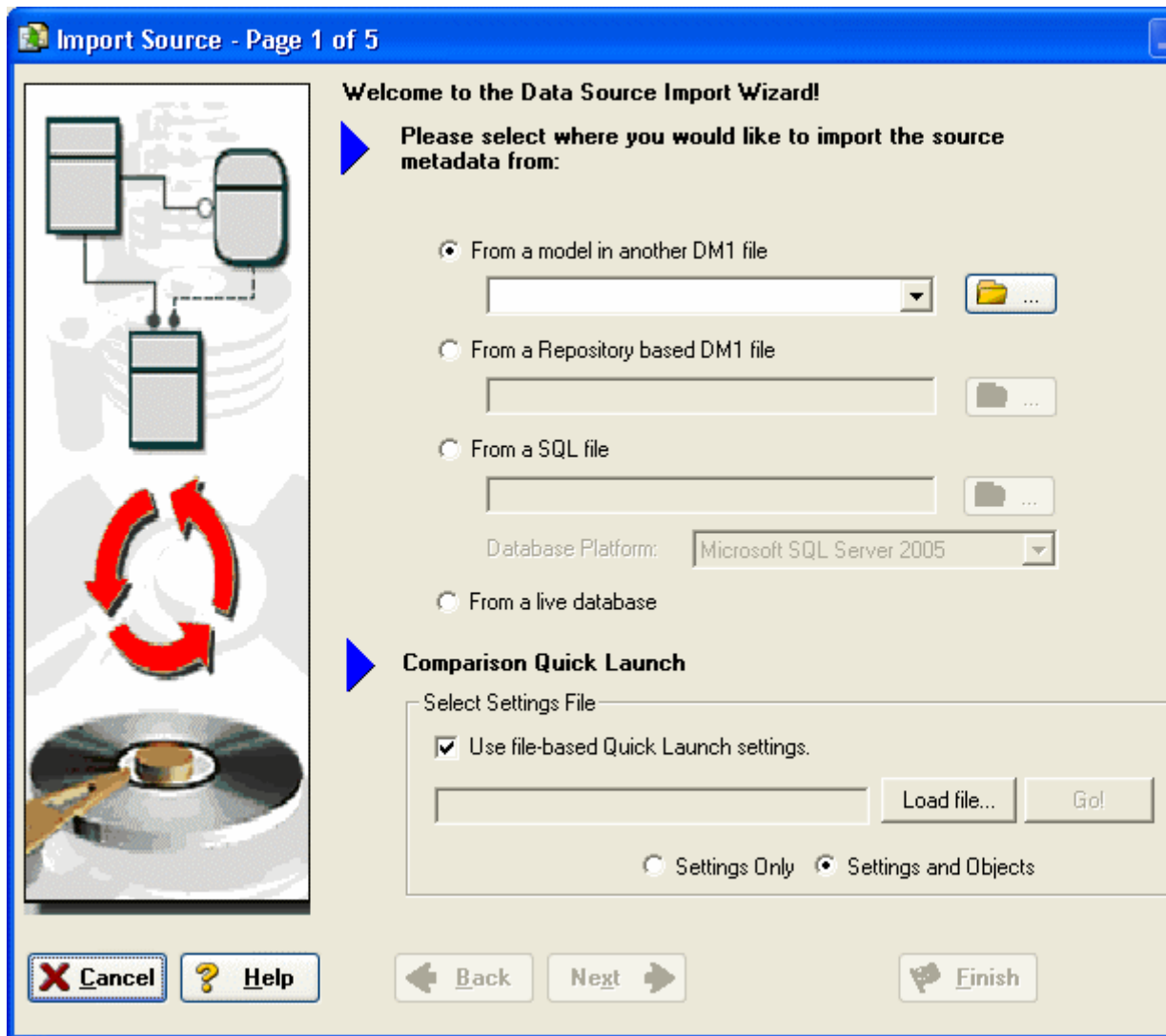

- 3 Complete the **Import Source** wizard as required and then click **Finish** to import the source. The new source will appear under the Other Sources node.

The following describe options that require additional explanation:

Page 1 - Please select where you would like to import the source metadata from

- **From a Repository based DM1 file:** Lets you obtain source from data models and Named Releases managed within the ER/Studio Repository. When you select this option, ER/Studio® Data Architect opens the Repository Operation Status dialog box and the Get From Repository dialog box. This process connects to the current Repository Server defined in the Repository settings. The Import Source wizard automatically gets the diagram.
- **From an SQL file** ER/Studio® Data Architect imports the SQL file.
- **From a live database:** If you select this option, a page appears where you can select the database and connection type. The connection type can be either ODBC or Native/Direct Connection. For information about connecting to databases, including troubleshooting information, see "Connecting to Database Sources and Targets" in the User Guide..
- **Comparison Quick Launch:** The Compare Quick Launch data is saved as an *.rvo file. For information on using the Quick Launch option in the wizard, see "Saving and Using Quick Launch Settings" in the *User Guide*.

Page 5 - Results

- **Current and Target Model Display Grid:** Between the Source and Target models is a Resolution column. The default merge decision is Merge the data into the new source file. You can click on any item in the Resolution column to enable the decision list. If you want to change the decision, click the list and then click the new resolution. When you change the default resolution of an object, the decisions of their dependent properties and objects are automatically updated. You can also click the category folders, like the Tables Resolution column to change all the decisions for all the underlying objects in that object category. And, you can use the CTRL key to select multiple items, and then right-click to enable the decision list.
- **SQL Difference:** To enable the SQL Difference utility, select any difference that is a long text field, such as a Definition, Note, or DDL, and then click SQL Difference to view the differences between the SQL of the models. This utility only allows you to view the differences; difference resolutions are performed on the Results page of the Compare and Merge Utility.
- **Filter Report on Results:** Create a report of the source content and your chosen resolutions. You can choose to create an HTML or an RTF report.

TIP: You can modify the default display using the options at the bottom of the page.

CREATING A DATA LINEAGE AND TRANSFORMATION VISUALIZATION

- 1 To create the data source or transformation input tables, expand **Data Sources > Local Models > Logical > Entities** and then drag and drop the **Broker** and **Investment** tables onto the Data Lineage window.
- 2 To create the data target or transformation output tables, navigate to **Data Sources > Local Models > GIM_DW** and then drag and drop the **Broker** table onto the Data Lineage window.

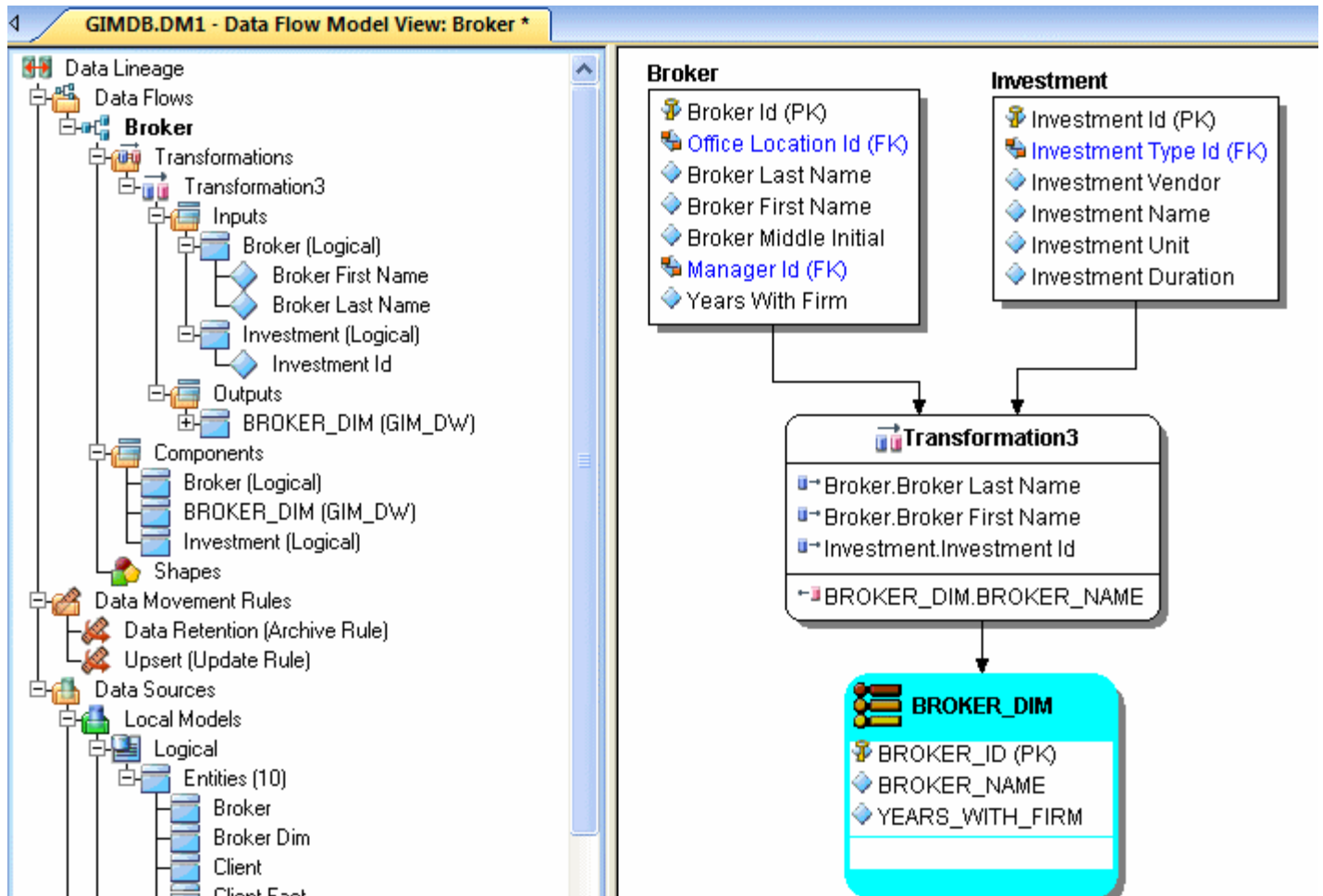

- 3 To obtain the Transformation insertion tool, right-click an empty space in the Data Lineage window and then click **Insert Transformation**.
- 4 To insert the transformation, click in the Data Lineage window between the source and target data sources and then right-click to drop the Transformation Insertion tool.
- 5 Reposition and resize the transformation object to suit your needs.
- 6 Right-click an empty space of the Data Lineage window and then click **Insert Data Stream**.

TIP: Transformation and Data Flow tools are also available on the toolbar. Hover the mouse over the tools to find the tool you need.

- 7 Click an input and then click the transformation object. Repeat as many times as necessary to link all the inputs to the transformation object.
- 8 Click the transformation object and then click an output.

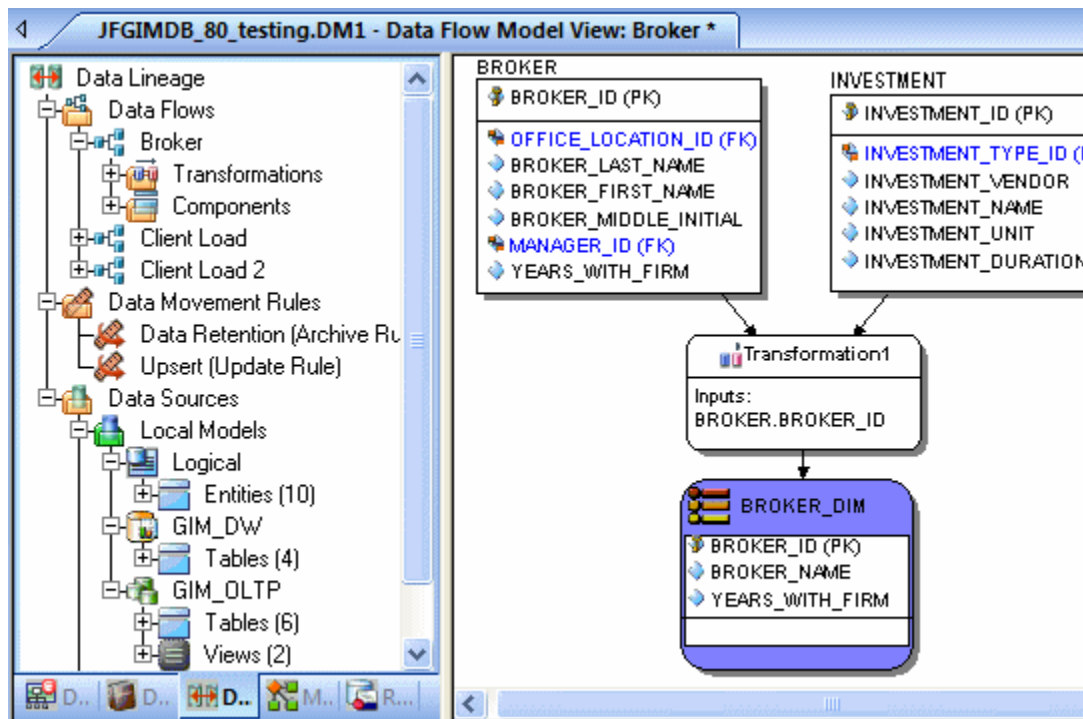

TIP: If the Inputs and Outputs do not display in the diagram as they do in the illustration above, choose **View > Diagram and Object Display Options > Transformation** and then click **Input and Output Columns**.

- 9 To define which columns should be used in the transformation and any transformation rules, double-click the new transformation to open the **Transformation Editor**.

10 Complete the **Transformation Editor** as required and then click **OK** to exit the editor.

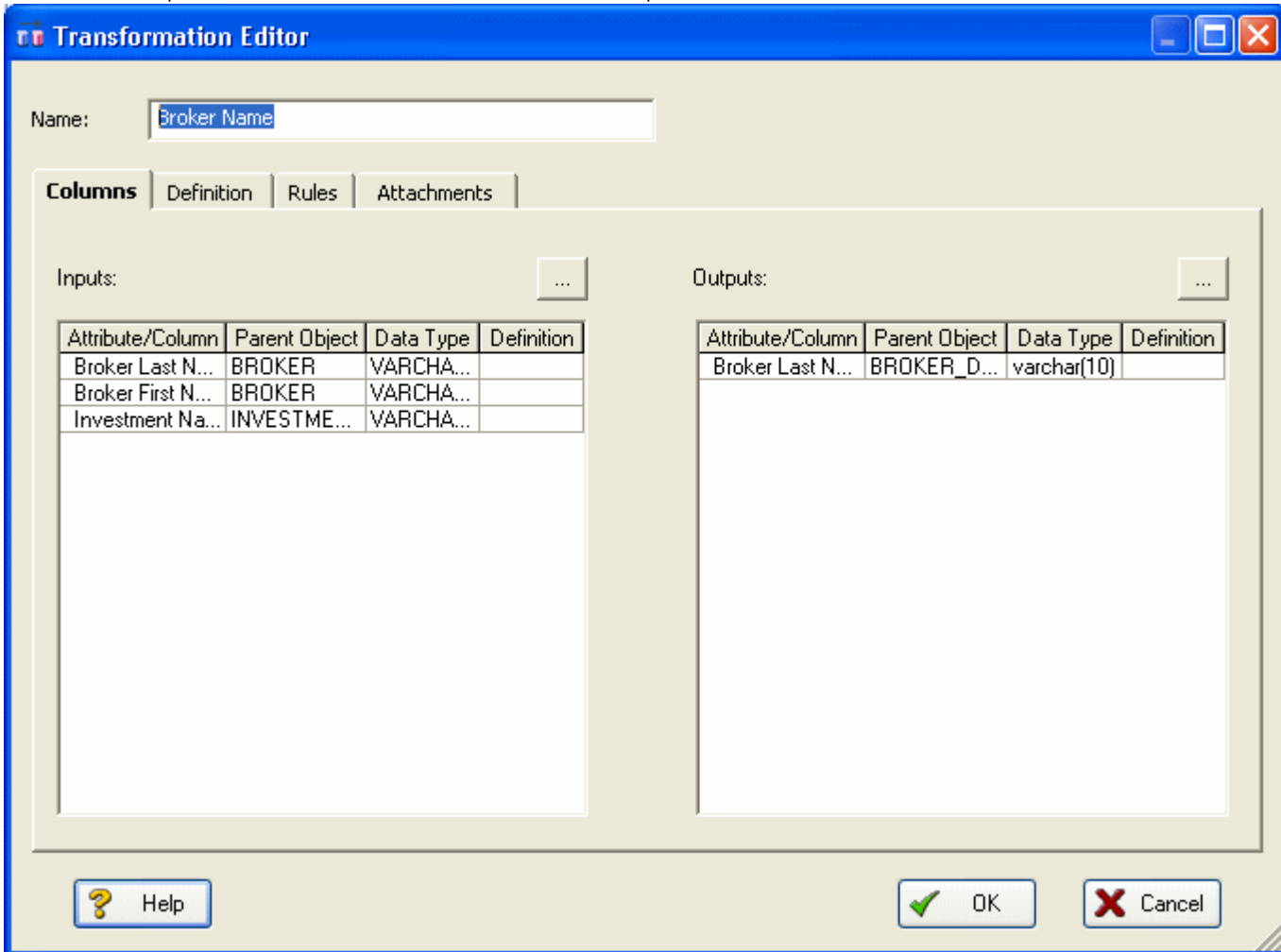

You are done! Now you can more easily share your ideas with your colleagues!

TIP: Once the Data Flow is created, you can double-click it to change its name, or double-click a transformation or component to change its properties.

The following describes options in the Transformation Editor that require additional explanation:

Columns tab

- **Inputs:** Click the ellipsis (...) button to choose the inputs to be transformed in this task.
- **Outputs:** Click the ellipsis (...) button to choose the outputs resulting from the transformation.

Definition tab

- **Business:** Describe the transformation for your audience.
- **Code:** Enter the code that will perform the transformation, such as a **SELECT** statement, or a VBasic or Java Script function or procedure.

Data Movement Rules tab

These are the rules from the Data Movement Rules node of the Data Lineage Explorer.

NOTE: You can delete or edit an input or output column by double-clicking the transformation in the Data Lineage window, clicking the ellipsis in the Transformation Editor and then deselecting the column you want to remove.

Attachments tab

Bind an external piece of information or attachment to the transformation. You can also remove an attachment from an object, override the default value of an attachment, or change the position of a bound attachment. To override the value of the attachment you have moved to the Selected Attachments grid, double-click the Value field of the target attachment. ER/Studio® Data Architect opens the Value Override Editor or a list, depending on the attachment datatype. Attachments are created in the Attachments folder of the Data Dictionary and must be applied to the default before they will display on this tab.

DIAGRAM NAVIGATION AND AESTHETICS

To assist with the creation of presentation-quality diagrams that are easy to navigate and are aesthetically pleasing, ER/Studio® Data Architect offers progressive diagram Auto Layout and Navigation utilities that also help you to clean up complex diagrams. Modelers should spend time solving complex database or business data model problems, not forcing boxes and lines to look a certain way.

NAVIGATING THE DIAGRAM

To demonstrate some of ER/Studio® Data Architect's layout and navigation utilities, we will import a sample SQL script provided with ER/Studio® Data Architect.

- 1 Close any files you have opened.
- 2 Choose **File > New**.

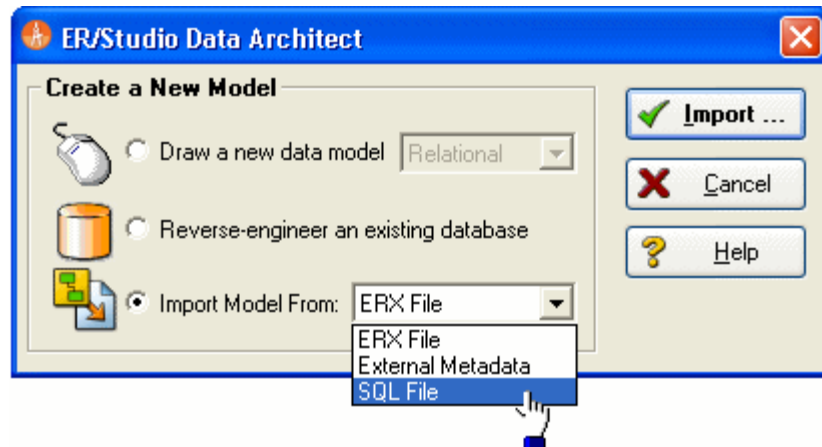

- 3 Select **Import Model From:** and then in the import list, click **SQL File**.

NOTE: The ERX File choice enables you to import Computer Associates ERwin 3.5.2 ERX files. The From External Metadata launches the MetaWizard to import from alternative sources.

The Import Database SQL File dialog appears:

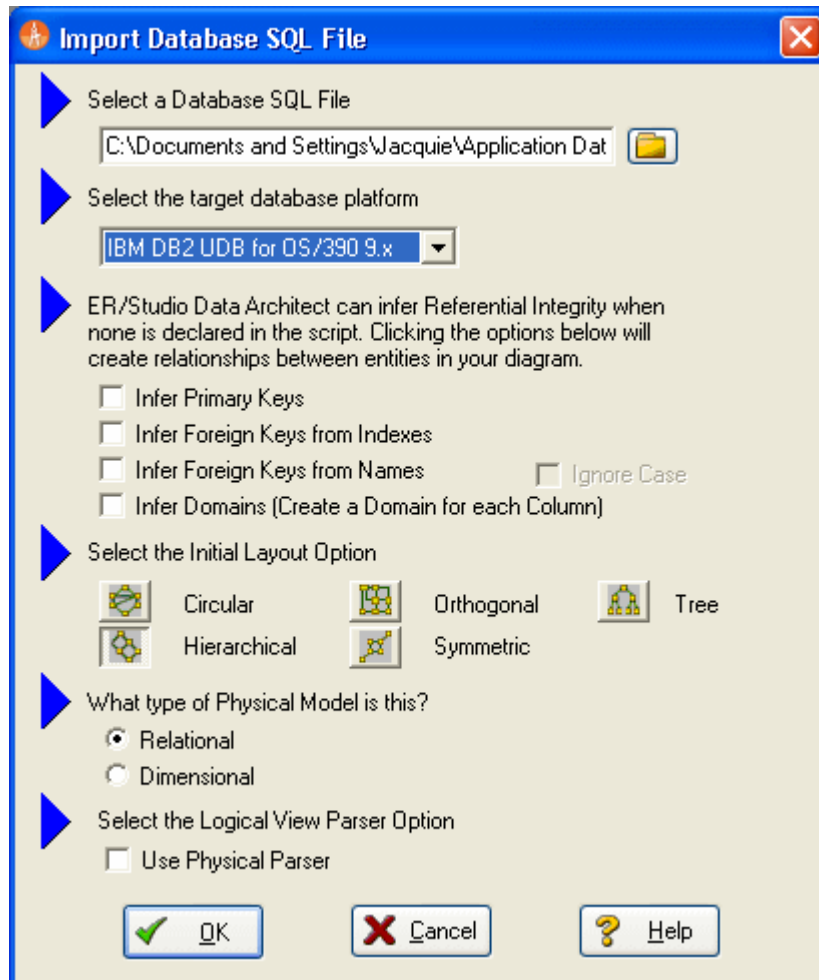

- 4 To the right of **Select a Database SQL File** click the folder icon, click **IBM DB2 OS390.SQL**, and then click **Open**.

The full path to this file is:

For Windows XP:

C:\Documents and Settings*<user>*\Application
Data\Embarcadero\ERStudio\SQLCode

For Windows Vista:

C:\Users*<user>*\AppData\Roaming\Embarcadero\ERStudio\SQLCodeSample

- 5 In the **Select the target database platform** list, click **IBM DB2 UDB for OS /390 9.x**.

6 Click **OK**.

Finished! Once the SQL Script is finished importing (as depicted below) the following items will assist you in leveraging a variety of Auto Layout and Navigation Features.

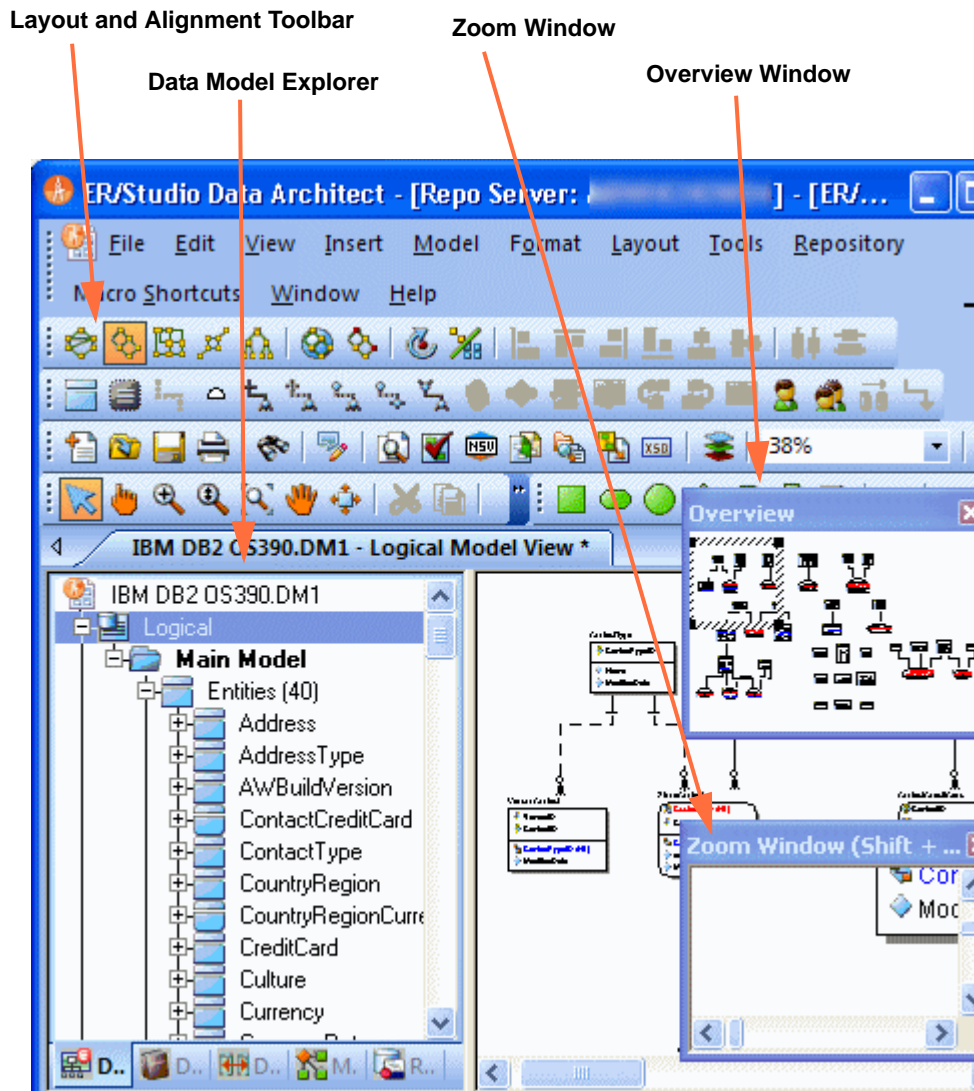

Layout and Alignment Toolbar: Use any of the four Auto Layout styles to change the layout of the diagram with the click of a button. The auto layout styles are all entirely customizable styles. You can also customize the diagram layout via the Layout Properties pages that can be launched by choosing Layout > Layout Properties.

- **Data Model Explorer:** Click on any object in the Data Model Explorer and it will automatically be selected in the diagram and focused in both the Zoom and Overview windows.
- **Overview Window:** Use this window as a thumbnail of your model to pan the entire model or zoom in and out. It can also pan and zoom the diagram if grabbed or sized. If the Overview Window is not already visible, press the F9 key to activate it.

- **Zoom Window:** Use this window as a magnifying glass to enlarge any diagram objects under your mouse cursor. You can also press SHIFT+F8 to freeze the zoom window to keep a single object frozen while you continue to pan around the diagram. If the Zoom Window is not already visible, press F8 to activate it.

DIAGRAM AESTHETICS

One of the tremendous benefits of building data models is the wide range of audiences that can realize value from them. Part of this relies on what information is displayed on the diagram. Depending on the audience you may want to limit or expand what is displayed. For example, developers may benefit from looking at a model that displays data type, null option, and unique and non-unique index information, while business analysts may just need the entity name and the definition. ER/Studio® Data Architect offers many display properties that can be customized exactly for this purpose.

Continuing with the previous section, we will use the DB2 model that was built to demonstrate some of the ways to customize the appearance of the model.

We will use the Diagram and Object Display Options dialog on the Diagram toolbar to further customize the view of the logical and physical models.

NOTE: You can use the Colors & Fonts tool to customize the look and feel further of each model.

SETTING THE LOGICAL MODEL DISPLAY

- 1 Select the logical model and then on the **Diagram Toolbar**, click the Diagram and Objects Display Options tool.



- 2 In the **Diagram And Object Display Options** dialog, click the **Entity** tab, and then in the **Display Level** area, select **Entity**.

- 3 Click OK.

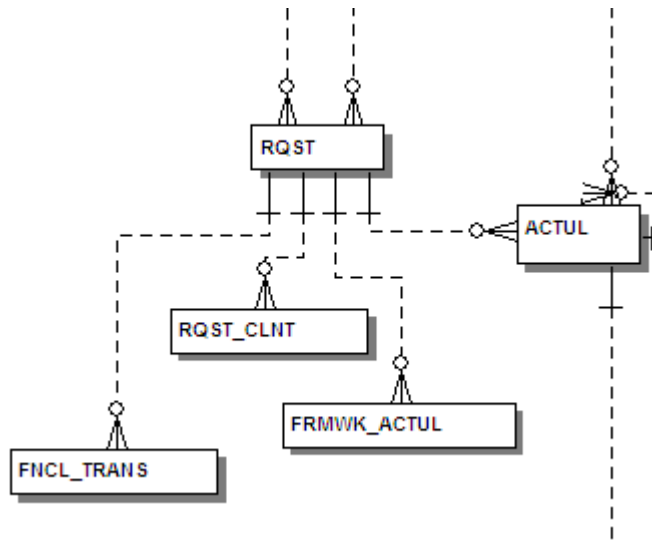

NOTE: Only entity names are displayed for each entity. You may also want to re-layout the diagram since the entity sizes have changed.

SETTING THE PHYSICAL MODEL DISPLAY

- 1 Select the physical model and then choose **View > Diagram and Objects Display Options**.
- 2 In the **Diagram And Object Display Options** dialog, click the **Table** tab.

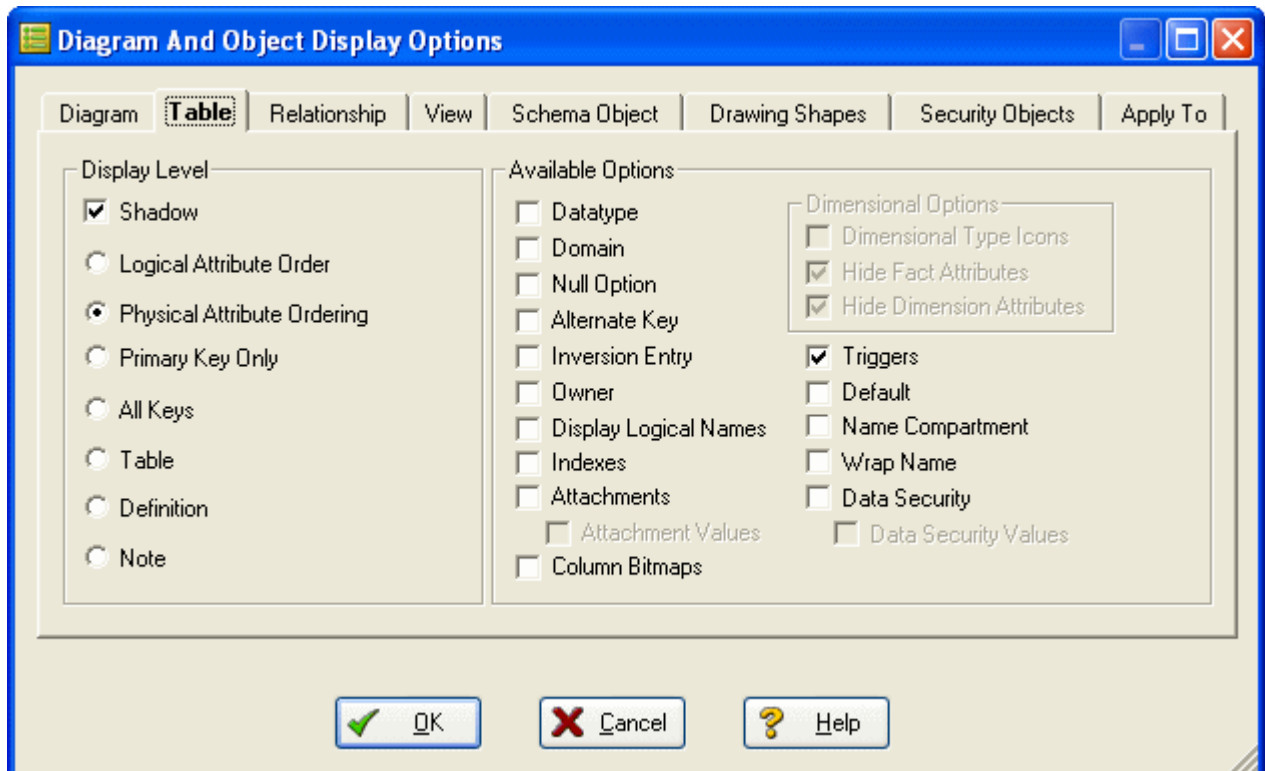

- 3 In the **Display Level** area, select **Physical Attribute Ordering**.
- 4 In the **Available Options** area, select the specific properties you want to display.
- 5 Click **OK**.

The model should now display more details for the physical model, as seen below.

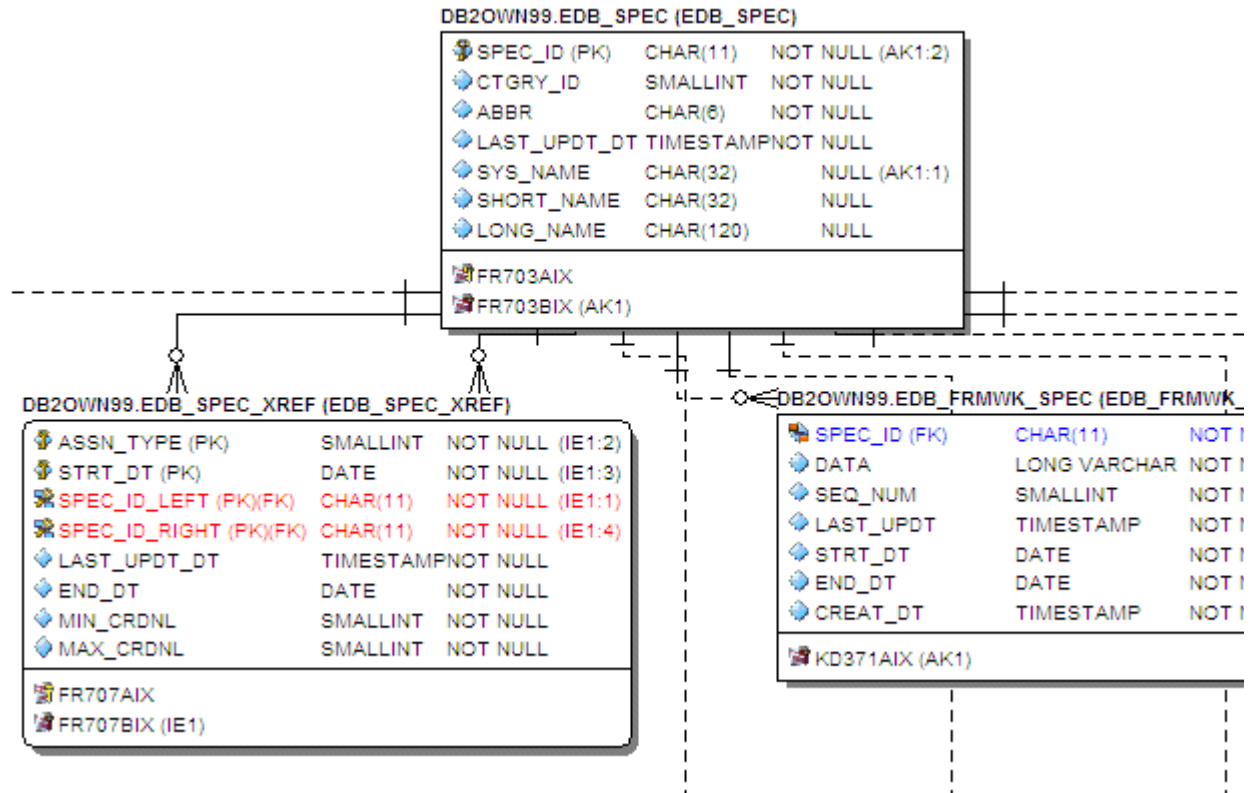

NOTE: Since the sizes of the objects changed, you may want to change the model layout using one of the ER/Studio® Data Architect advanced layout engines. You can also customize the default display properties for new models by choosing Tools > Options, and then selecting the desired options on the Display tab.

Conclusion

In this session, you have learned how to:

- Import an SQL file and allow ER/Studio® Data Architect to automatically create a diagram.
- Use a variety of auto layout and navigation tools to enhance the aesthetic experience of the diagram and to improve the data model navigability.
- Customize the display of both the logical and physical models.

IMPORTING AND EXPORTING METADATA

The MetaWizard allows you to import and export metadata from a wide spectrum of sources and targets. Various metadata formats are supported that provide connectivity to environments such as XML Schemas and DTDs, OMG's CWM-XMI, and business intelligence repositories such as Business Objects, Cognos, DB2 Cube Views, and various UML and data modeling tools.

NOTE: The MetaWizard is a separately licensed module. For evaluation purposes the Import Bridge is enabled during the install, but the Export Bridge is not. Contact Sales@Embarcadero.com to enable the Export Bridge for evaluation.

IMPORTING METADATA

Let's walk through an example of how to build a model from a specific metadata source. In this case we will use OMG CWM XMI 1.1, one of the popular formats used by various modeling tools.

- 1 Close any open files.
- 2 To launch the Import MetaWizard, choose **File > Import File > From External Metadata.**

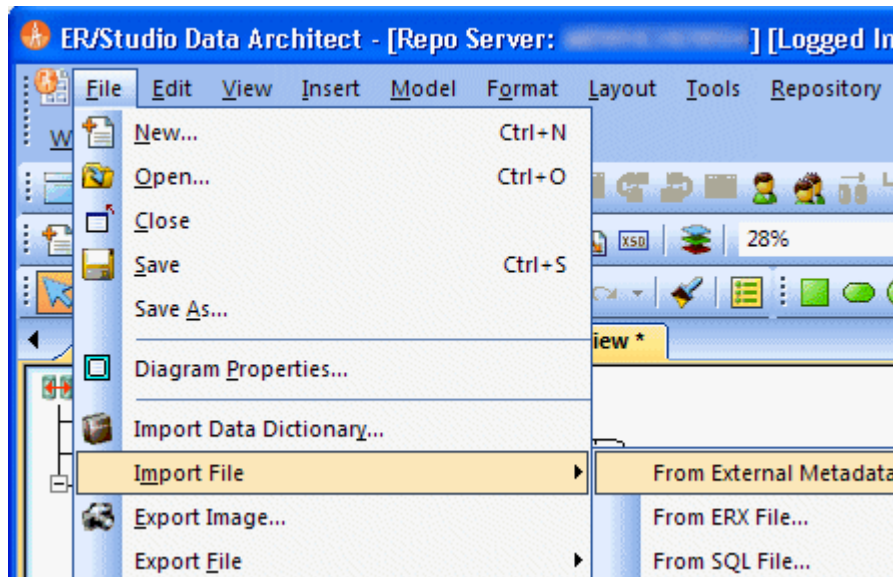

- 3 To select the external metadata, in the **Type** list, click **OMG CWM 1.xXMI 1.x.**
 - Next to **From**, click the folder icon and browse to the Sample Models directory, select OrangeMart (XMI).xml, and then click Open.

The sample models are located at:

- **Windows XP:**
C:\Documents and Settings\All Users\Application Data\Embarcadero\ERStudioDA_X.X\Sample Models

- **Windows Vista:**

C:\ProgramData\Embarcadero\ERStudioDA_X.X\Sample Models

Each environment has specific versions that determine how the metadata is translated. When importing models or metadata from another source of your own, ensure you select the appropriate platform and version.

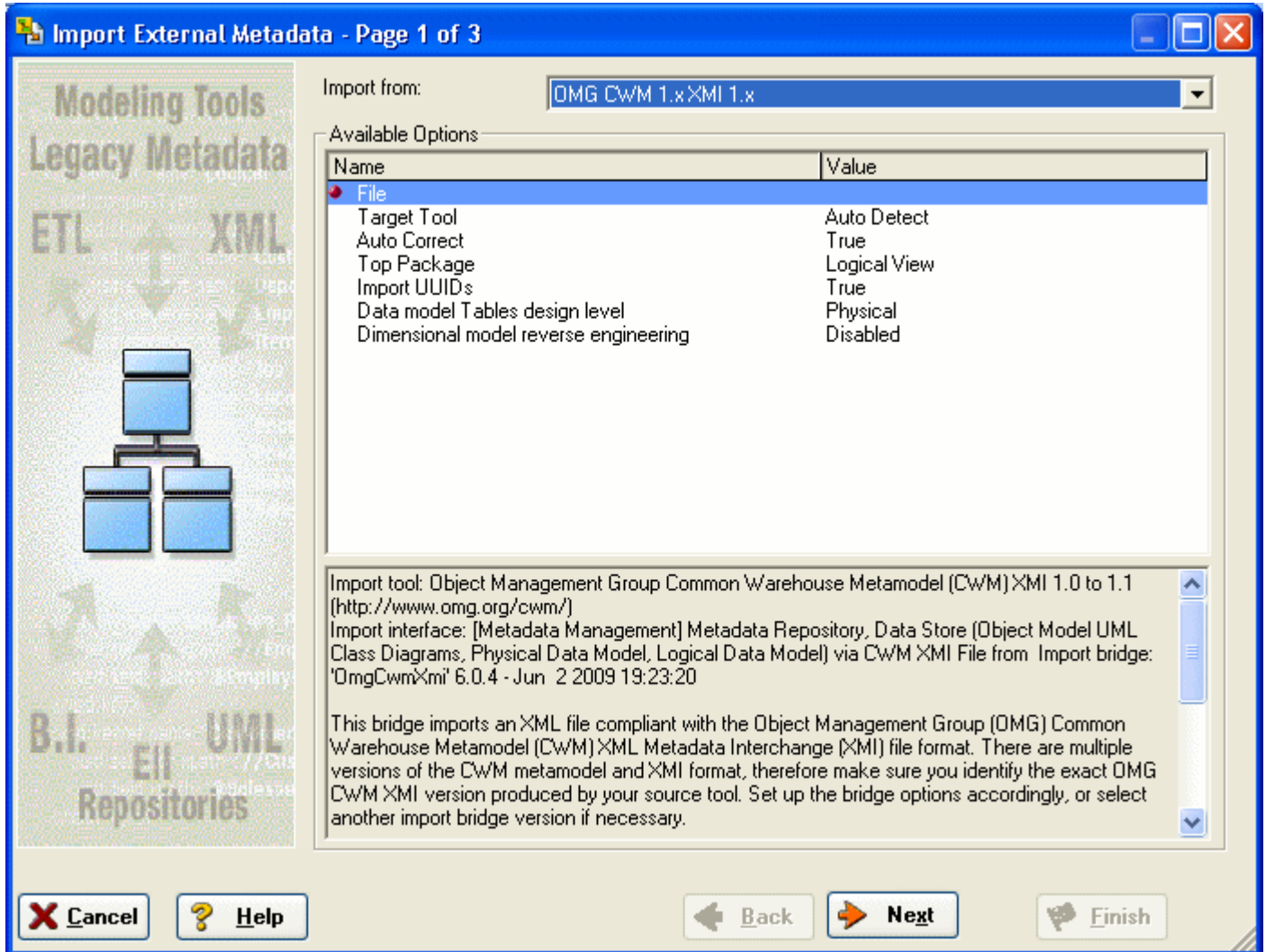

- Click **Next**, click through page 2, and then on page 3 click **Finish**.

By default the MetaWizard performs a basic consistency check of the file imported and reports any inconsistencies on page 2 of the wizard.

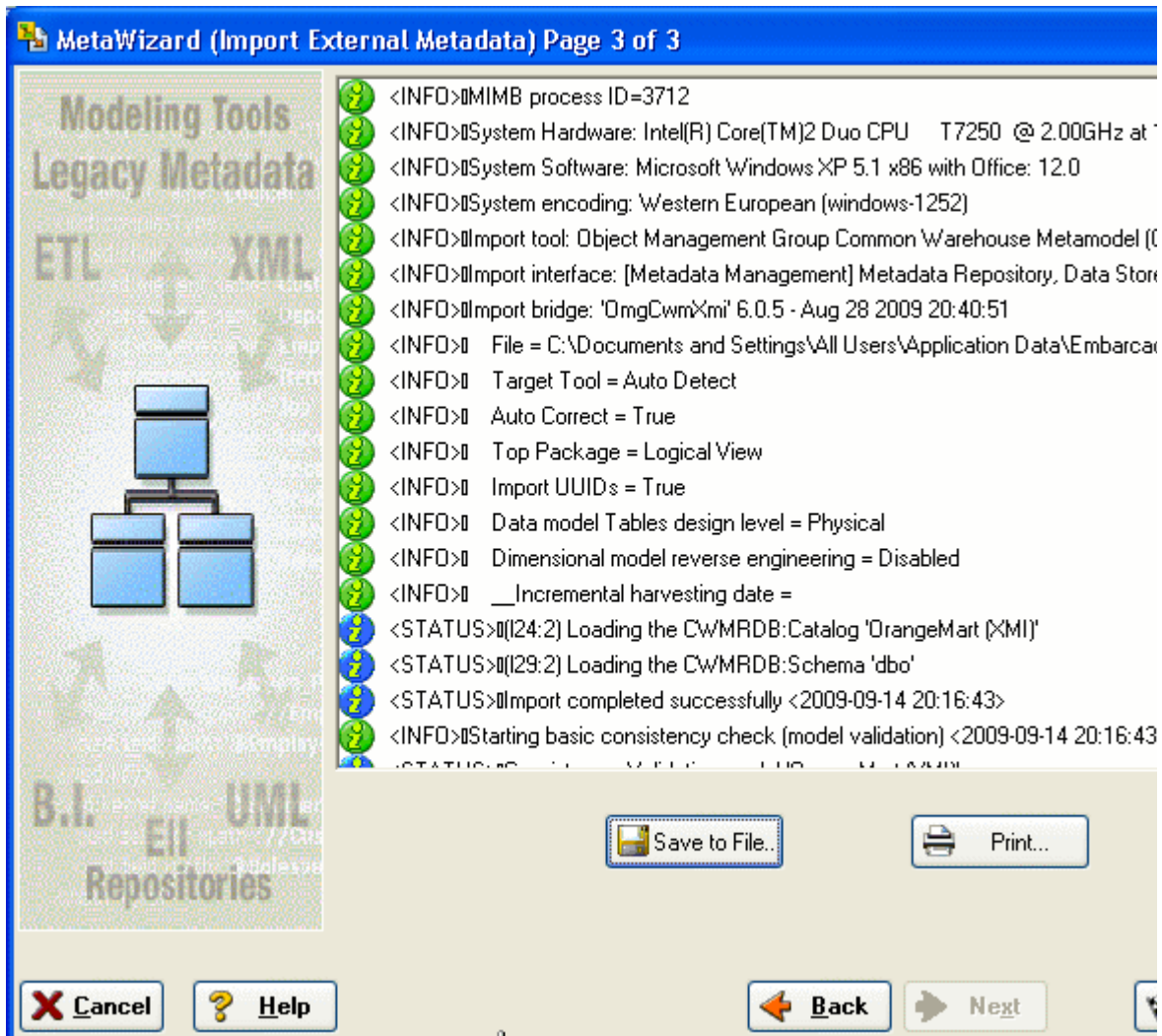

The MetaWizard builds a logical and physical model based on the source metadata.

- Choose **File > Save** and then specify a filename.

Please keep this model for use in "[Dimensional Modeling](#)" on page 52 of the tutorials.

NOTE: In some cases the layout will not import from the source metadata. If this happens you can use one of ER/Studio® Data Architect's advanced layout engines as described in a previous section.

EXPORTING METADATA

NOTE: This feature is not supported by the Developer Edition of ER/Studio.

ER/Studio® Data Architect can export metadata in the same formats from which it can import. Metadata can be exported from the entire diagram by choosing **File > Export** or by right-clicking any of the submodels or the main model and choosing **Export Model Metadata**.

Let's walk through an example of exporting. we will use the model that was built from the XML file. In this example we want to export the diagram metadata to Business Objects so you can use the metadata to generate reports.

NOTE: You need a separate license for the Export Bridge for use in this exercise.

- 1 Choose **File > Export File > Export Diagram Metadata**.

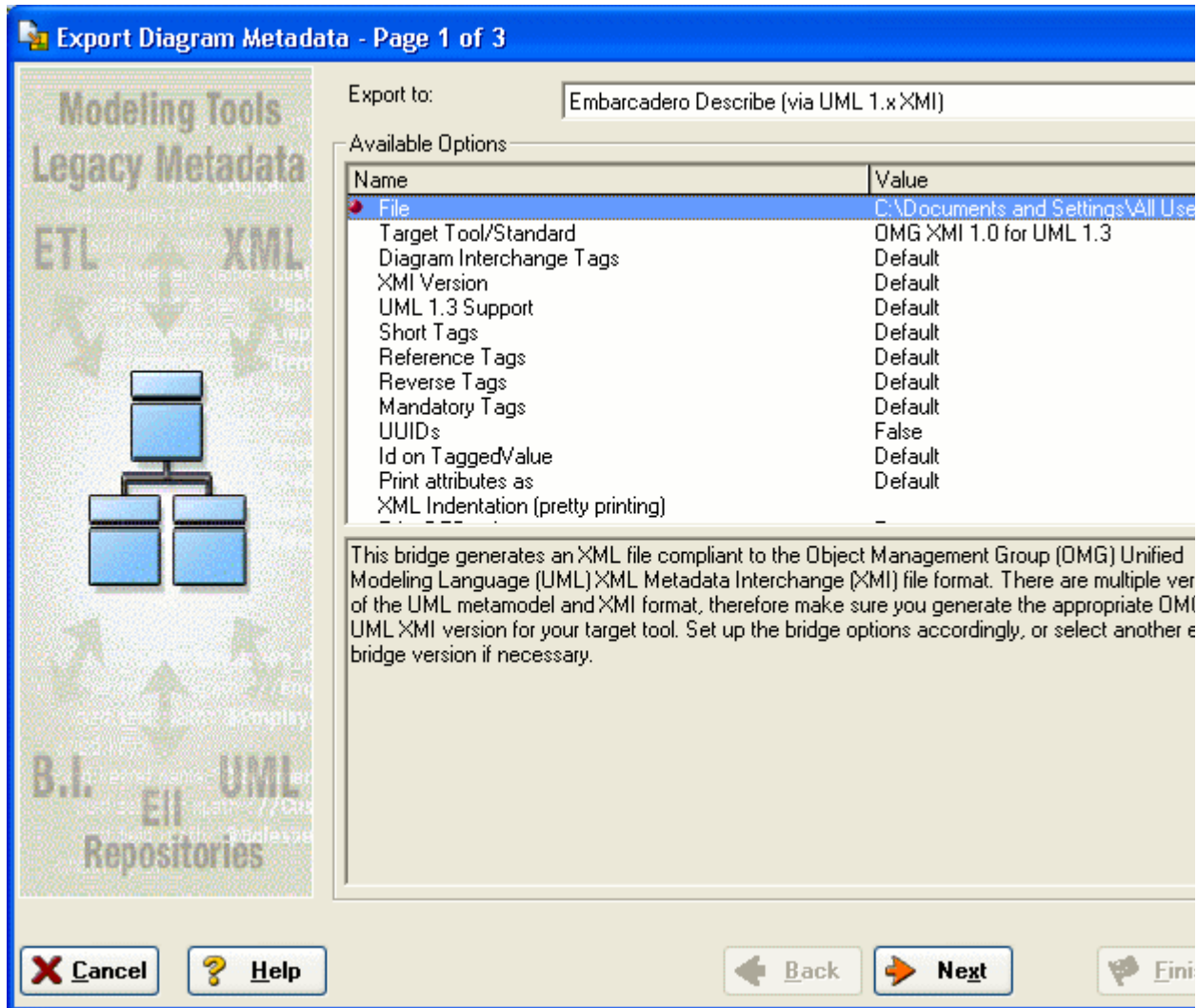

This launches the Export Bridge.

- 2 To select the output type:

- In the **Type** list, click **Business Objects Data Integrator**.
- Next to **Save To**, click the folder icon and browse to a file location for the XML file, enter a filename, and then click **OK**.

3 Click **Next**.

This will run a check on the exported metadata.

4 Click **Finish**.

This will save the file to the specified location. We will use this file in the next tutorial.

Conclusion

In this session we've explored the metadata management capabilities of ER/Studio® Data Architect, specifically how to:

- Import metadata from a wide range of sources to produce a logical and physical model.
- Export metadata to an equally wide range of formats so that metadata can be shared with other groups within your organization.

DIMENSIONAL MODELING

ER/Studio® Data Architect allows you to model dimensional structures such as star and snowflake schemas that can be leveraged for data warehouses, data marts, and OLAP. ER/Studio® Data Architect's dimensional notation helps you to visualize and build these complex models by using icons for the various table types, and enforcing rules specific to dimensional modeling standards. This session will help you construct a dimensional model and walk you through some of the aspects inherent to dimensional notation.

OVERVIEW OF DIMENSIONAL NOTATION

First, let's create a dimensional model. There are a number of ways you can designate a model as dimensional.

DESIGNATING A MODEL AS DIMENSIONAL

If you are creating a new model you can designate the model as dimensional in one of the following dialogs:

- On **Page 5** of the **Reverse Engineer Wizard**.
Choose **File > New**, select **Reverse-engineer an existing database**. Login to the database, click **Next** to page 5, and then in answer to **What type of Physical Model is this?**, select **Dimensional**.
- In the SQL Import dialog.
Choose **File > Import file from SQL file**, and then in answer to **What type of Physical Model is this?**, select **Dimensional**.

- On **Page 1** of the **Generate Physical Model Wizard**.

Right-click the Logical model, select **Generate Physical Model**, and then in answer to **What type of Physical Model is this?**, select **Dimensional**.

If you have an existing physical model, you can change the type in Model > Model Options. For the purpose of this session, we will use the model created from the XMI file in the Import Metadata session. If you skipped that session, go back to "[Importing and Exporting Metadata](#)" on page 48 and walk through the Import Metadata section.

Since we already have an existing model, we will just change the notation.

- 1 Choose **File > Open**, navigate to the physical model you saved in "[Importing Metadata](#)" on page 48, and then click **Open**.
- 2 Right-click the physical model and then click Model Options.
- 3 In the **Model Notation** area, select **Dimensional**.

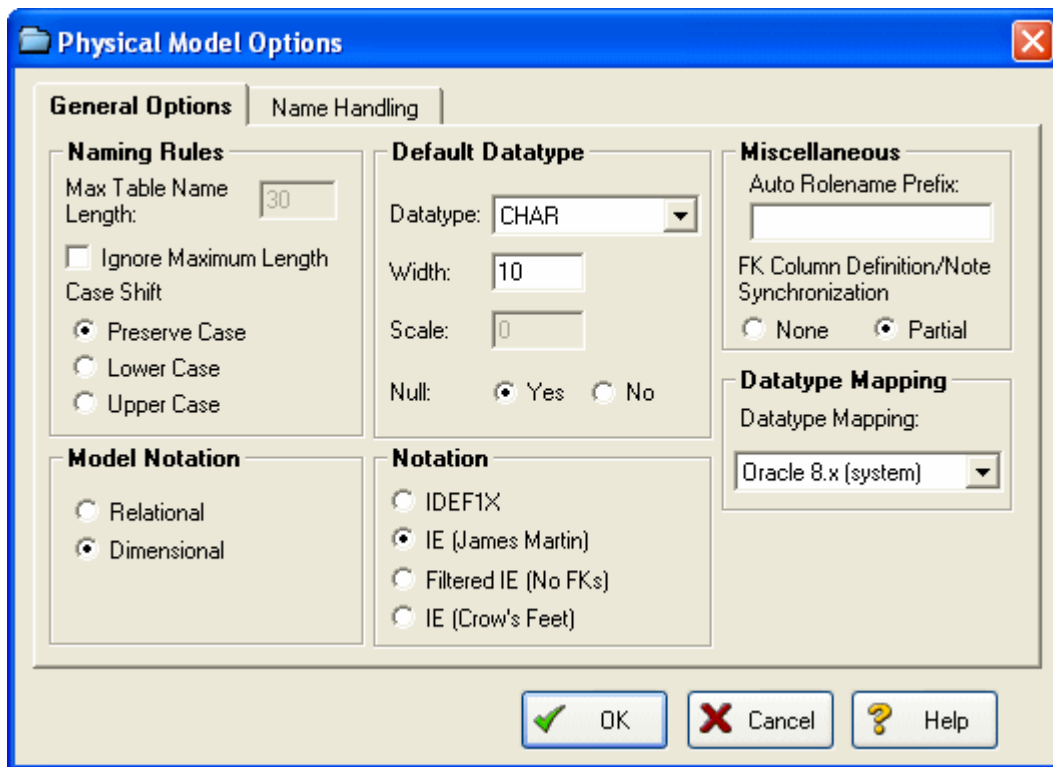

- 4 Click **OK**.

Now that we've changed the model notation, we can use an auto-layout tool to rearrange the tables.

- On the Layout and Alignment Toolbar, click the **Hierarchical Layout** tool.

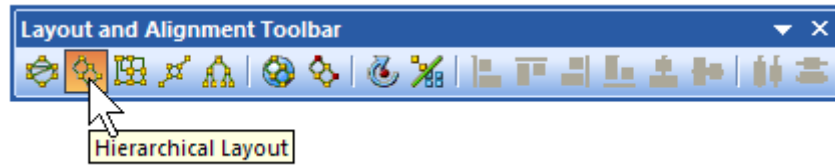

Notice that the look and feel of the tables has changed and each table has a specific icon depending on the type of table ER/Studio® Data Architect determines it is. ER/Studio® Data Architect analyzes the foreign key chains of the model and uses dimensional modeling rules to decipher fact tables of dimension, snowflake, and or other dimensional tables.

The illustration below gives an overview of dimensional notation.

Icons in the Data Model Explorer correspond to table type in the model. The same icon will appear in the upper-left corner of each table.

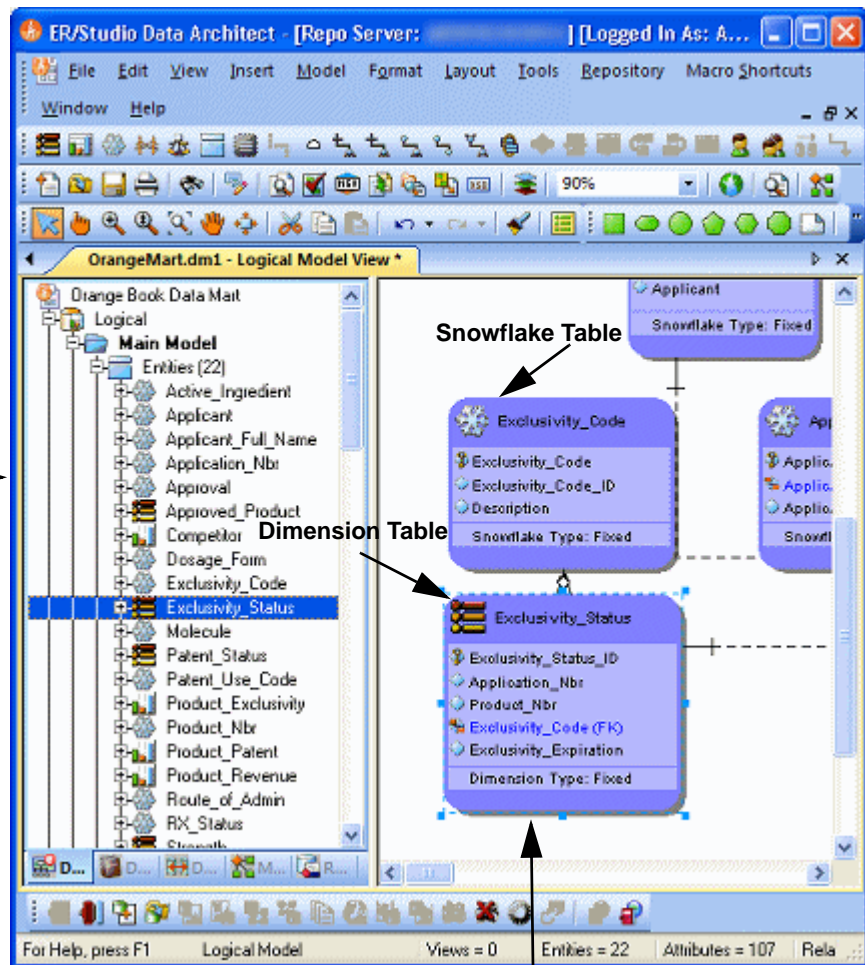

Dimension Type display information

WORKING IN A DIMENSIONAL MODEL

Notice in the previous screenshot that ER/Studio® Data Architect determined that Product_Patent is a fact table, Approved_Product is a dimension table and the parent tables of Approved_Product are snowflakes. This is because Product_Patent has no child tables, Approved_Product is a parent of Product_Patent, and the parent tables of Approved_Product are two relationships away from the perceived fact table. Analyzing this a little further, it looks like Approved_Product is actually the fact table, Product_Patent could be a bridge to another fact table, and the parents of Approved_Product are actually qualifiers of Approved_Product or dimensions. The table type can be changed to override how ER/Studio® Data Architect originally interpreted the table.

Let's walk through an example. With the physical model from the previous example selected, let's edit the Approved_Product table.

- 1 To open the Table Editor, double-click the **Approved_Product** table.
- 2 Click the **Dimensional** tab.
- 3 In the **Dimensional Model Table Type** list, click **Fact**.

TIP: There are other dimensional model type tables such as Bridge and Hierarchy Navigation. Click the list to see the other table types.

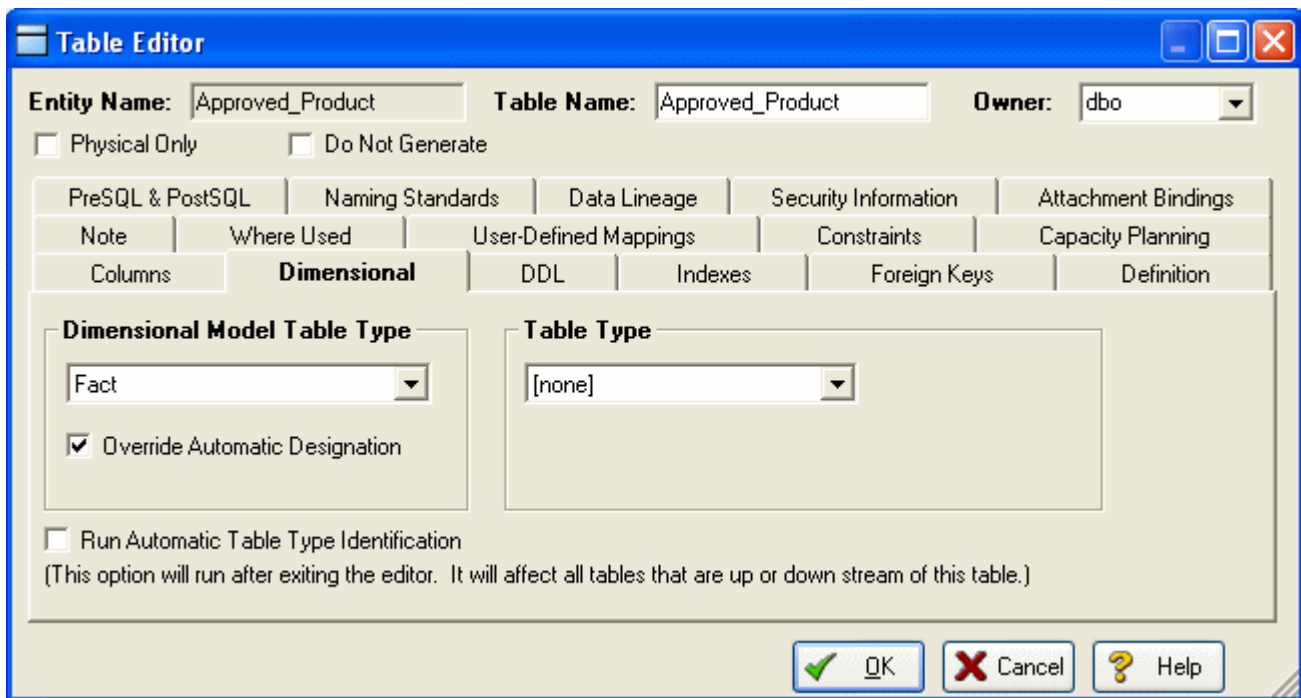

- 4 Ensure the **Override Automatic Designation** option is selected.
- 5 Select the **Run Automatic Table Type Identification** option.
- 6 Click **OK**.

TIP: You can change the designation of a table without affecting related tables by deselecting the Run Automatic Table Type Identification option.

The result is that Approved_Product becomes the Fact table. The parent tables of Approved_Product will all become dimension tables and the Product_Patent table will be designated as undefined. As another exercise, select another dimensional table and change the type of dimension depending on the desired data refresh rate as in the following illustration.

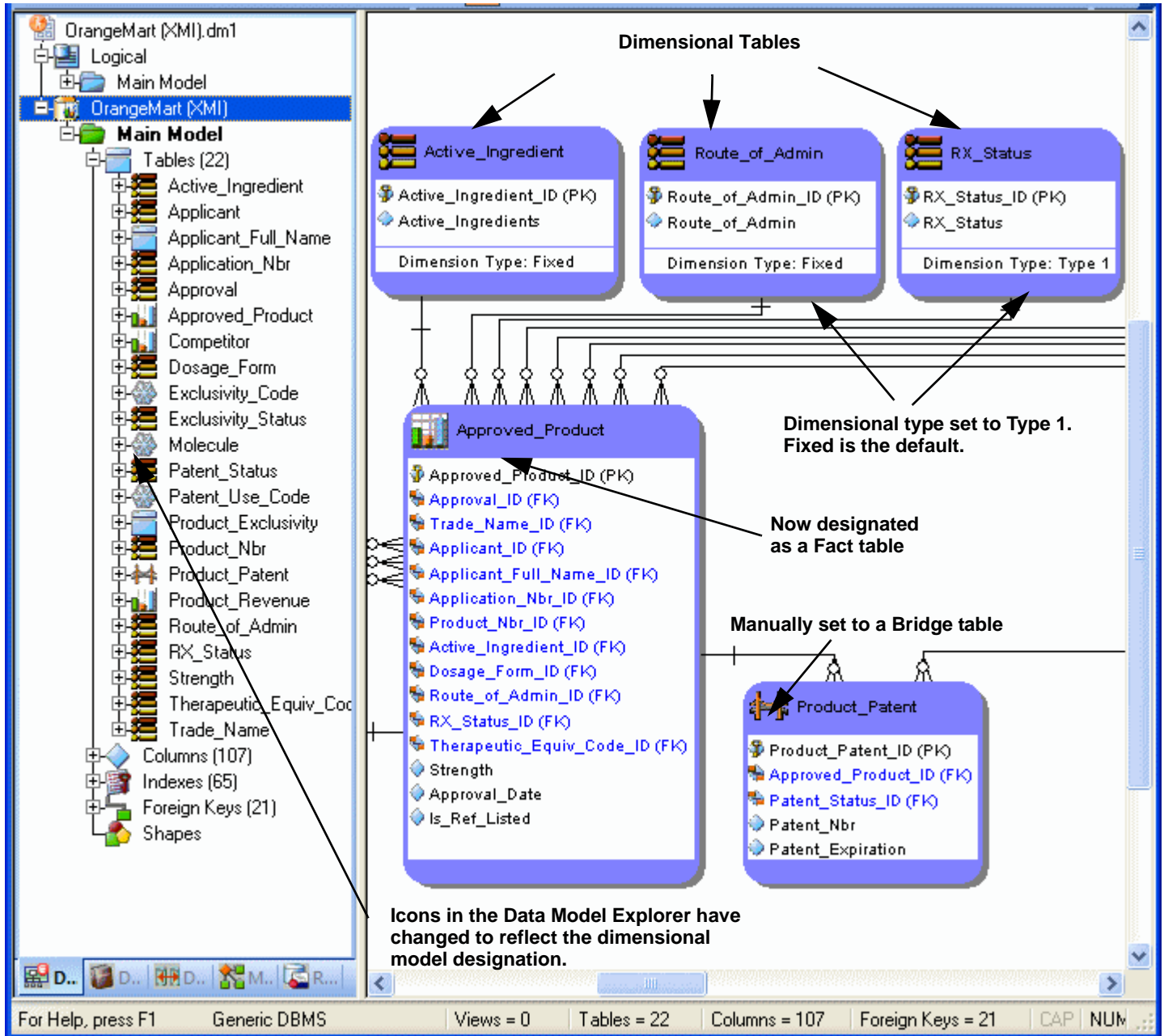

AUTOMATING TASKS

ER/Studio® Data Architect is equipped with a well-documented Automation Interface. The automation interface is driven by the Sax Basic language (a derivative of the Visual Basic for Applications language) and serves many purposes, fundamentally enabling you to customize ER/Studio® Data Architect through an application interface.

There are two main reasons to employ the Automation Interface:

- **Automate Routine Tasks:** Automate tedious, routine modeling tasks or customize ER/Studio® Data Architect to enforce modeling practices in your organization. For example, you can write a macro that will automatically colorize child tables that contain propagated foreign keys. Or, you can write a macro to automatically insert a specific name and primary key into new entities as they are created.
- **Collaborate with Other Applications:** ER/Studio® Data Architect models contain valuable metadata that you can access from applications such as Microsoft Excel, Access, and Outlook. Using ER/Studio® Data Architect's automation interface, you can collaborate with any external application that has an exposed API or its own automation interface.

In this walk-through, we will demonstrate an example of how to leverage ER/Studio® Data Architect's automation interface to dramatically increase modeler productivity. You will not be writing any Sax Basic (VBA) code in this walk-through. You will be running a macro that is included with the product. You can write your own macros using the Sax Basic Integrated Development Environment included in ER/Studio® Data Architect.

CREATING MACROS

Using the Sax Basic integrated development environment, you can expand upon the functionality offered in the sample macros provided or create macros to automate model development and maintenance.

To access the Sax Basic development environment, choose **Tools > Basic Macro Editor**.

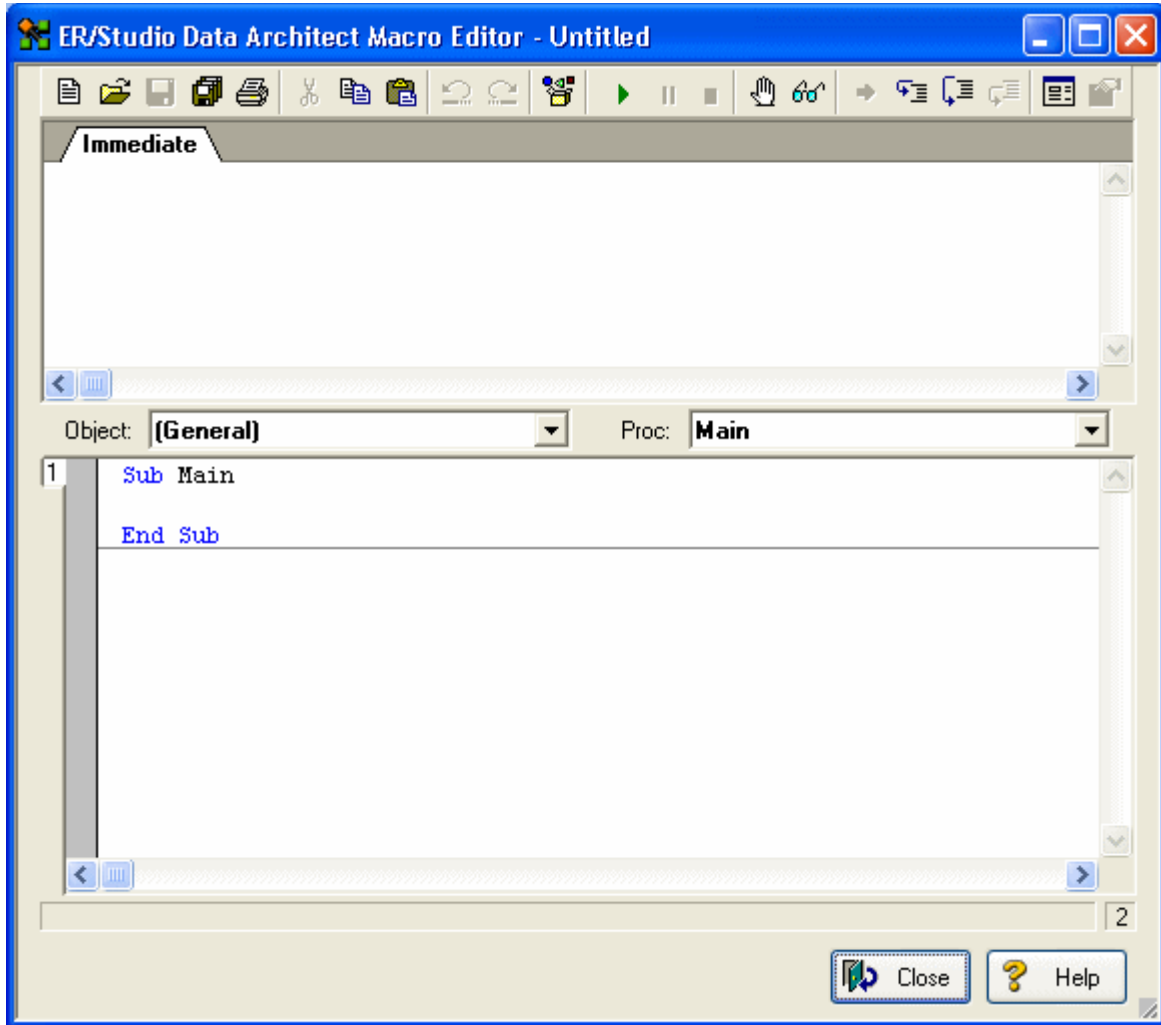

TIP: The automatic appearance of lists as you type, allows you to select and insert ER/Studio® Data Architect Automation Objects. After inserting an object, you can get information about the object by selecting it and then clicking the Browse Object tool on the application toolbar.

USING MACROS TO AUTOMATE THE MODELING PROCESS

You can use Visual Basic macros to speed development and enforce the re-use of metadata.

In this example, we will be leveraging macros provided with the product to demonstrate powerful Automated modeling activities you can benefit from.

- 1 Close all open diagrams.
- 2 Choose **File > New** and then select **Draw a New Data Model**.
- 3 In the **Data Model Explorer**, click the **Macros** tab.

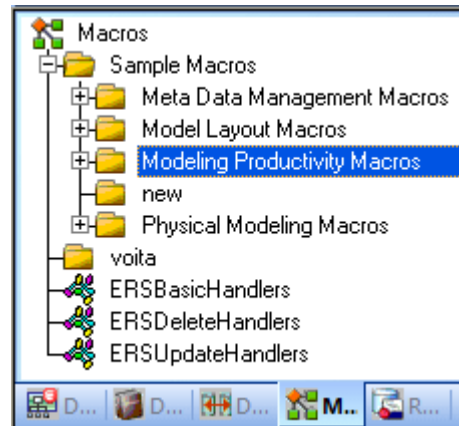

- 4 In the **Modeling Productivity Macros**, locate the **Auto-Create Data Dictionary** macro.
- 5 Right-click the **Auto Create Data Dictionary** macro and then click **Run Macro**.

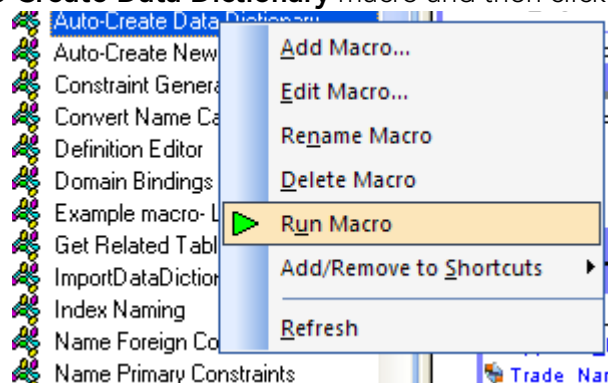

Running this macro will create a set of Domains in the Data Dictionary which the next macro run will leverage. (For more information on Domains, see "[Logical and Physical Modeling](#)" on page 6).

- 6 With the set of Domains now ready, create an entity on the **Data Model Window**.

TIP: For a refresher on creating an entity, see "[Using Data Dictionary Domains to Populate New Entity](#)" on page 7.

- 7 Name the entity, **Person**.

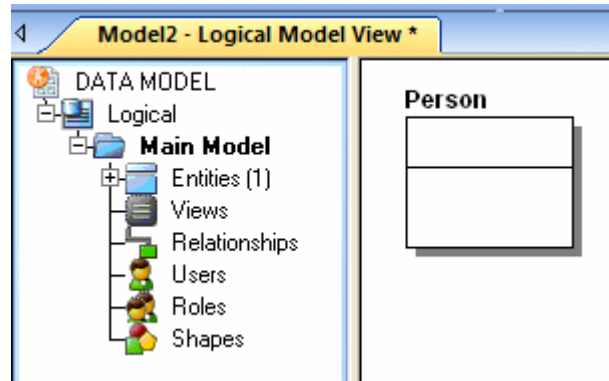

You do not need to implement any attributes for the Person entity at this time.

- 8 Select the **Person** entity and in the **Modeling Productivity Macros** folder, right-click **Add Base Attributes To Person Entity** and then click **Run Macro**.

NOTE: The macro automatically created all of the attributes for Person entity for you!

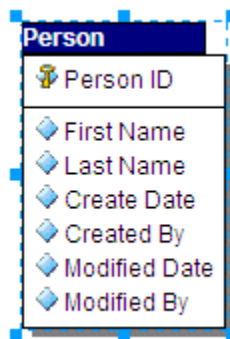

You have just:

- Saved the effort of manually typing these standard attributes into selected entities that require them.
- Bound all the new attributes to Domains for proper standard enforcement.

You can customize these macros in any way you choose! This example merely stresses how to increase the productivity of modelers to automate repetitive tasks such as ensuring entities conform to the same standard set of attributes. Feel free to explore the other macros we've included for you and see how they can increase your productivity.

Conclusion

In this session, you have learned how to:

- Access the Basic Macro Editor to create your own macros from scratch.
- Select the Macro tab of the Explorer Browser and launch sample macros included with ER/Studio® Data Architect to help increase modeler productivity.

For more assistance on the Automation Interface, refer to ER/Studio® Data Architect's Help and review the section on Automation Interface.

COLLABORATIVE MODELING

ER/Studio® Data Architect Enterprise includes a server-side component to ER/Studio® Data Architect designed to distribute work across modeling team members in a safe and controlled way, facilitating a real-time collaborative modeling environment and increasing productivity for teams out of the box. The solution implements utilities and features that enable concurrent modeling, version management for model and model objects, establishment of continually reusable data elements, and more. The secure, scalable environment is fully integrated with the current, natural workflow in ER/Studio® Data Architect. The Enterprise Portal enables you to easily browse the Repository, reporting on it, and commenting on model reports to provide feedback to other users. The Enterprise Portal is also integrated into ER/Studio and is accessible from the Repository tab.

This portion of the guide is intended to give a brief overview and walkthrough of ER/Studio® Data Architect Enterprise. It will start with the configuration of the Repository and the Portal and continue on to include inserting a diagram into the Repository, working with the diagram in the Repository, versioning the diagram, sharing and reusing objects across diagrams and applying security to your diagrams, and finally reporting on the diagrams through the Portal. It is intended as an introduction of the Repository. For more information please refer to the Repository section of ER/Studio® Data Architect's Help or contact Technical Support at Support@Embarcadero.com or call (415) 834 3131 x2.

This section contains the following topics:

- [Downloading and Installing ER/Studio Repository](#) on page 62
- [Downloading and Installing ER/Studio Portal](#) on page 62
- [Configuring Connection to Repository and Portal](#) on page 62
- [Exploring and Reporting on the Repository](#) on page 65
- [Adding a Diagram into the Repository](#) on page 67
- [Repository Status Icons](#) on page 69
- [Organizing Diagrams Through the Repository Project Center](#) on page 70
- [Checking Out Diagrams vs. Checking Out Objects](#) on page 71
- [Checking Out at the Object Level](#) on page 72
- [Checking Out at the Diagram Level](#) on page 76
- [Creating Different Versions of a Diagram](#) on page 77
- [Applying Security to Diagrams through the Security Center](#) on page 79

DOWNLOADING AND INSTALLING ER/STUDIO REPOSITORY

To evaluate the collaborative modeling benefits of ER/Studio® Data Architect Enterprise, you will need to download and install a separate installation executable. You can download the Repository installation executable from the Embarcadero Web site at:

www.embarcadero.com/downloads

You need to download the ER/Studio® Data Architect Enterprise zip file or the ER/Studio® Data Architect Standard Upgrade to Enterprise executable.

ER/Studio® Data Architect Enterprise requires installation on an RDBMS of your choice: DB2 LUW, Oracle, Sybase ASE or Microsoft SQL Server. Two components will be installed: the server and the database. The server machine requires the chosen database client utilities to be installed in advance so that the server can initially build and subsequently connect and communicate with the database thereafter.

- For comprehensive installation instructions, including Repository server requirements and database sizing projections, please refer to the Install Guide.
- For information regarding ER/Studio® Data Architect Architecture, see “Understanding and Maintaining the Repository” in the *ER/Studio Data Architect UsersGuide*.

Install guides are available on Embarcadero.com:

docs.embarcadero.com

DOWNLOADING AND INSTALLING ER/STUDIO PORTAL

To evaluate ER/Studio Portal, you will need to download and install a separate installation executable. You can download the Portal installation executable from the Embarcadero Web site at:

www.embarcadero.com/downloads/download.html

ER/Studio Portal requires installation on an RDBMS of your choice: Oracle, IBM DB2 LUW, and Microsoft SQL Server. Three components are installed: the server, and the reporting and solution databases.

For comprehensive installation instructions, see the *ER/Studio Portal Installation Guide*.

CONFIGURING CONNECTION TO REPOSITORY AND PORTAL

- 1 Install the ER/Studio Repository.
- 2 Install the ER/Studio Portal

- 3 If the **Repository** menu is not visible on ER/Studio® Data Architect's Main menu, choose **Tools > Options > Repository Options**.

Otherwise, choose **Repository > Options**.

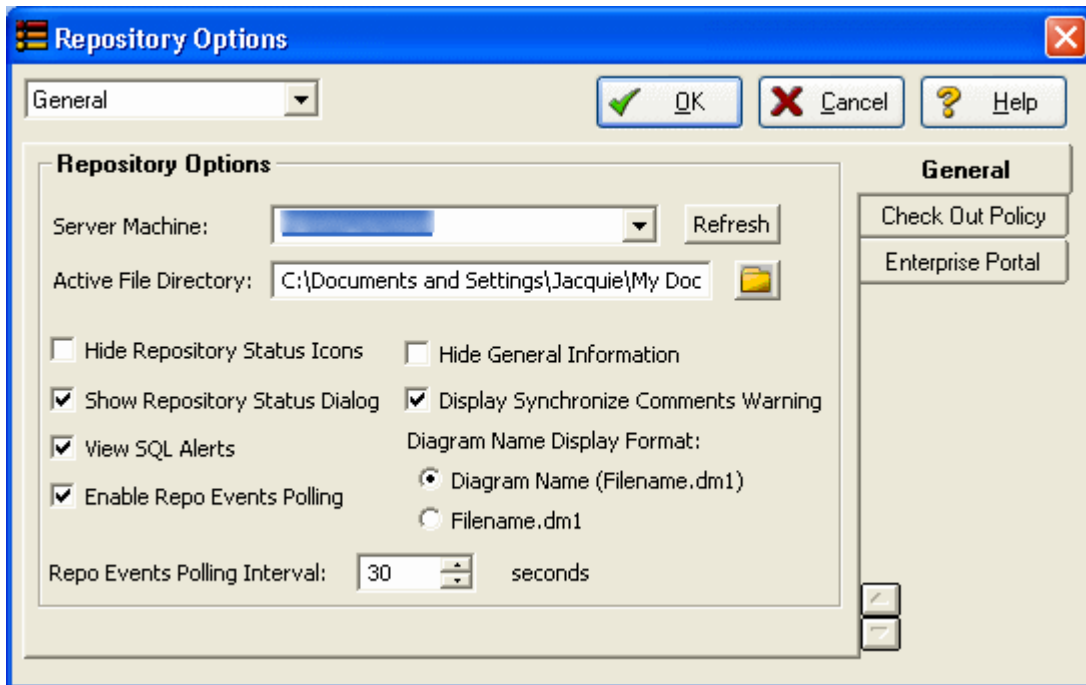

- 4 In the **Repository Option** area, click **Refresh** and ER/Studio® Data Architect will automatically detect Repositories already installed on your network. You can also manually enter the Repository Server machine name in the specified field.

NOTE: If the Repository list on the ER/Studio® Data Architect main menu is unavailable, check to see if you have a valid license. You can check this by choosing Help > About ER/Studio® Data Architect. This will display the names of the modules you have installed. If you do not see RepoClient or it is unavailable then you can request an evaluation extension to trial the software for 14 days. After that a permanent license is required.

- 5 In the **Active File Directory**, enter the directory path where the local ER/Studio® Data Architect DM1 diagram files will be saved.

ER/Studio® Data Architect manages a local working copy of the data model and submits changes you have made to this file to the Repository or, conversely, updates changes others have made from the Repository in order to update your locally managed file. All of this you control through the sophisticated Review Changes user interface.

NOTE: The Active File directory should be a directory on your local machine and not on a network location. You will need read/write privileges on this path.

- 6 In the **Repository Options** dialog, click the **Enterprise Portal** tab.
- 7 Enter the specifics of the Enterprise Portal you will be connecting to.

Connecting to the Repository

To connect to the Repository, choose **Repository > Log In**.

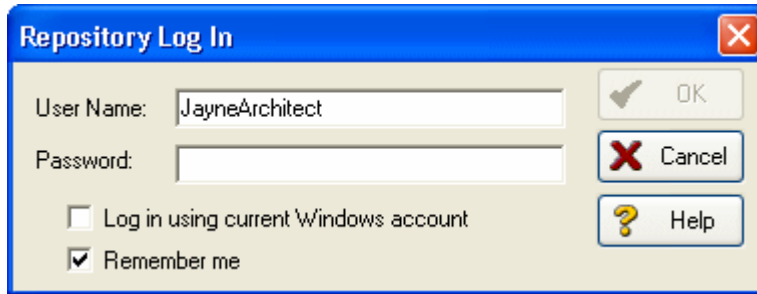

The screenshot shows a dialog box titled "Repository Log In" with a blue header and a red close button. It contains two text input fields: "User Name:" with the text "JayneArchitect" and "Password:". Below the password field are two checkboxes: "Log in using current Windows account" (unchecked) and "Remember me" (checked). On the right side, there are three buttons: "OK" with a checkmark icon, "Cancel" with a red X icon, and "Help" with a question mark icon.

The login dialog will prompt you for a user ID and password. The default login after installation is Admin and the default password is Admin. Both are case-sensitive.

Once you are connected to the Repository, you are ready to add diagrams.

Connecting to the Portal

To connect to the Portal, choose **Repository > Enterprise Portal Log In**.

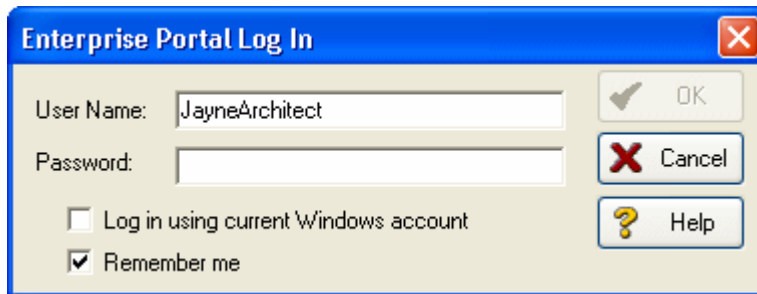

The screenshot shows a dialog box titled "Enterprise Portal Log In" with a blue header and a red close button. It contains two text input fields: "User Name:" with the text "JayneArchitect" and "Password:". Below the password field are two checkboxes: "Log in using current Windows account" (unchecked) and "Remember me" (checked). On the right side, there are three buttons: "OK" with a checkmark icon, "Cancel" with a red X icon, and "Help" with a question mark icon.

The login dialog will prompt you for a user ID and password. The default login after installation is Admin and the default password is Admin. Both are case-sensitive.

Once you are connected to the Portal, you are ready to explore the Repository and view model reports.

EXPLORING AND REPORTING ON THE REPOSITORY

Once you have logged in to the Portal, you can view the contents of the Repository through the Repository Explorer.

- 1 Click the **Repository** tab and then expand the **Projects** and **Samples** folder.

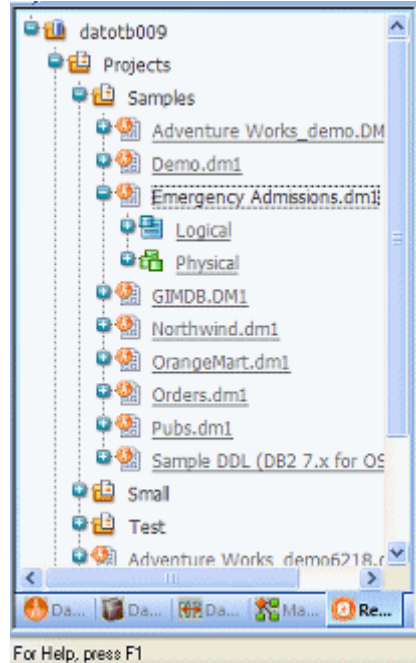

- 2 Click the name of a Diagram and the Diagram report appears in the Diagram Window.

View as report

Diagram: Emergency Admissions.dm1

Author: Embarcadero Product Management

Version: 1.0

Company: Embarcadero Technologies

File Name: Emergency Admissions.dm1

Project: Samples

Create Date:	11/29/2008 3:00:32 AM	Modified Date:	6/10/2009 AM
---------------------	-----------------------	-----------------------	--------------

Definition

Initial Reversed Database

Done ER/Studio Portal

- 3 In the Repository window, scroll through the Diagram report that displays and then click on a model name.

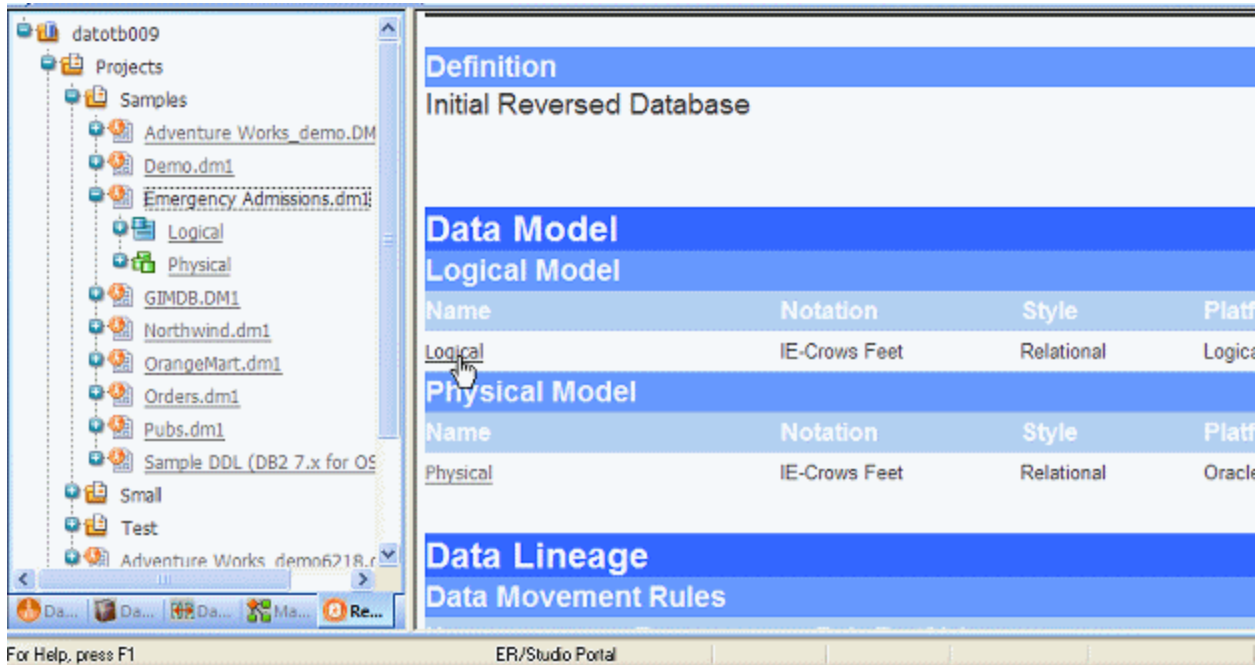

You can continue to drill down through the reports until the Entity level by clicking the links in the reports.

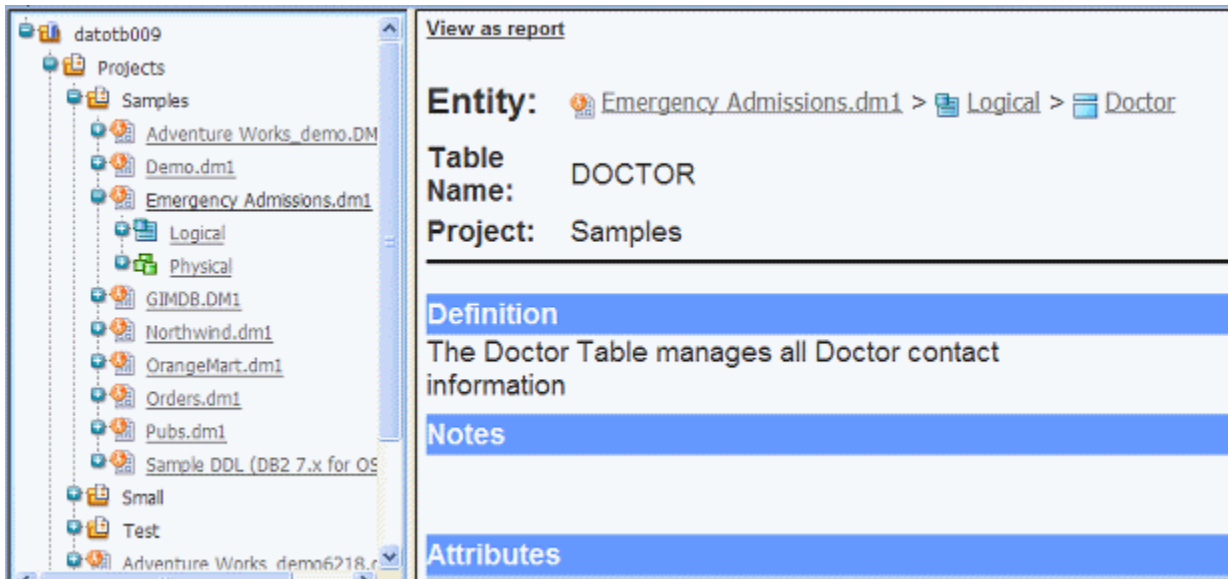

Notice that you can return to reports higher up in the diagram hierarchy by clicking the Model name or the Diagram File name.

- 4 Click **View as report**.

- In the **Related Reports** area, click the name of a related report, such as **Attribute Definitions**.

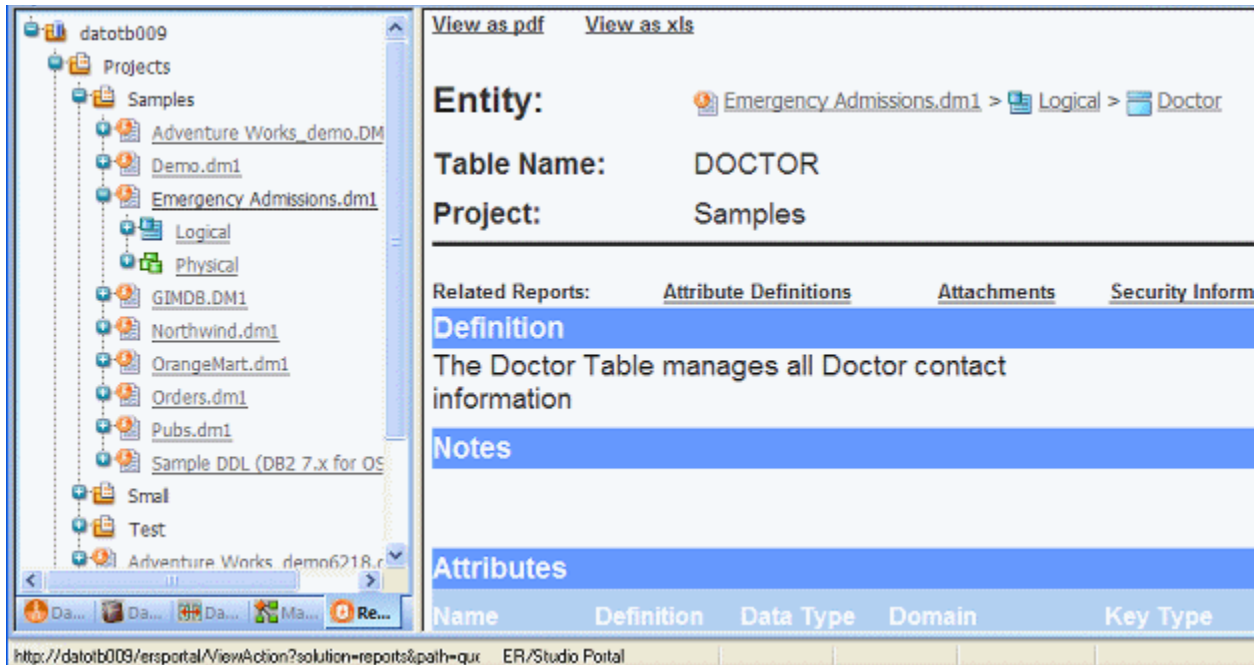

- Click **View as pdf**, and the report will display using Acrobat reader. From within Acrobat reader you can save or print the report, or attach files or comments to it.

Click **View as .xls**, and the report is saved in comma delimited format that is compatible with Microsoft Excel.

ADDING A DIAGRAM INTO THE REPOSITORY

- Choose **File > Open**.
- Browse to the **Sample Models** folder, select **Orders.dm1**, and then click **OK**.

The Sample Models folder is located at:

- Windows XP:
C:\Documents and Settings\All Users\Application Data\Embarcadero\ERStudioDA_X.X\Sample Models
- Windows Vista:
C:\ProgramData\Embarcadero\ERStudioDA_X.X\Sample Models

- 3 Once the diagram is opened, choose **Repository > Diagrams > Add Diagram**.

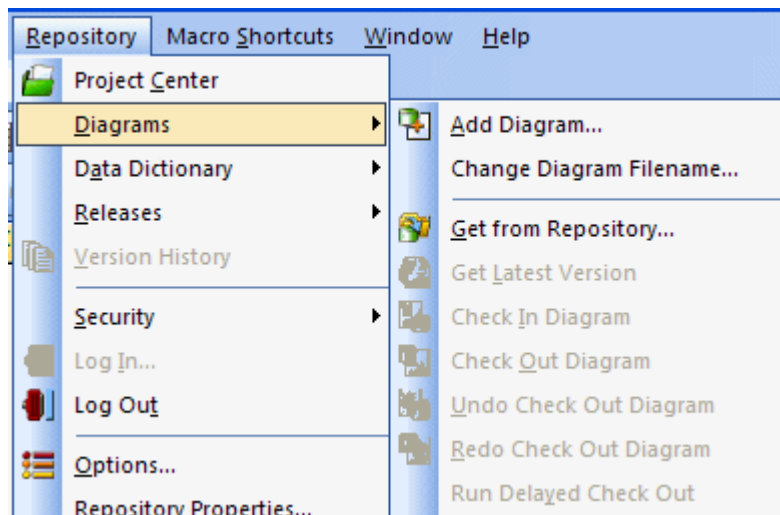

- 4 Fill in the appropriate information in the **Add Diagram to ER/Studio Repository** dialog.

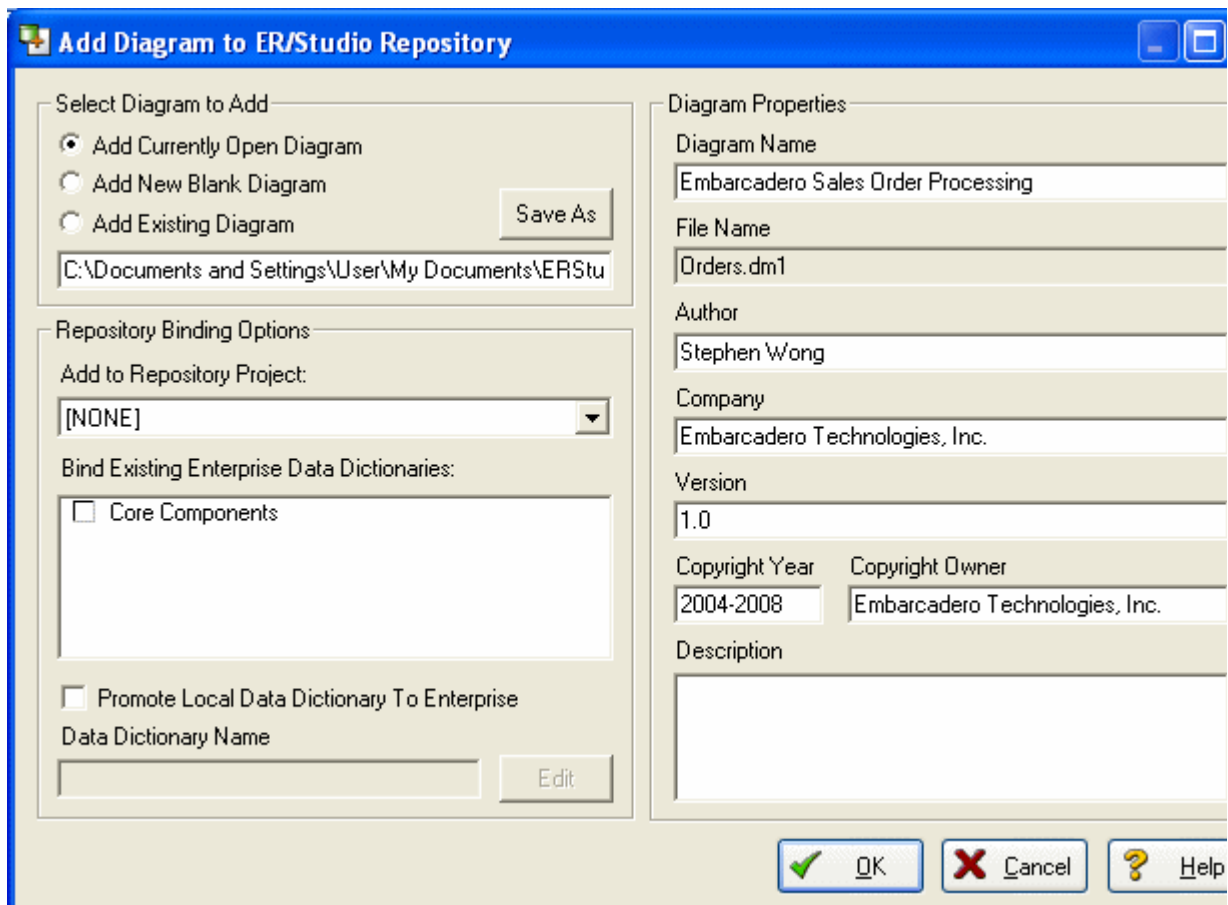

- 5 Optional. To assign the diagram to a project, below **Add to Repository Project**, select a project from the list.

- 6 Optional. To bind an enterprise data dictionary to the diagram, in the **Bind Existing Enterprise Data Dictionaries** area, select a data dictionary.
- 7 Click **OK**.

This will start the process of adding a diagram.

Once the Add Diagram operation is finished, you will see Repository status icons appear on the model objects (explained in Repository Status Icons). Now added, the diagram is available for any users who can connect to your Repository and who have been granted authorization.

REPOSITORY STATUS ICONS

Once the Orders diagram has been added to the Repository, Status Icons will appear in the Data Model Explorer next to the object name. These are the lock and monitor icons you see below.

- Lock icon: Indicates the real-time status of object metadata in the Repository, such as attributes, definitions, and storage properties.
- Monitor icon: Indicates the real-time status of display metadata, such as object color and font.

These icons indicate the check out status of the diagram and the objects in the models. Depending on what type of check out (exclusive vs. non-exclusive) and who has checked out the object (you locally vs. others remotely), the status icons will change to provide a real-time status of exactly who is doing what, and when, to a diagram object. A matrix of these icons is available in Help.

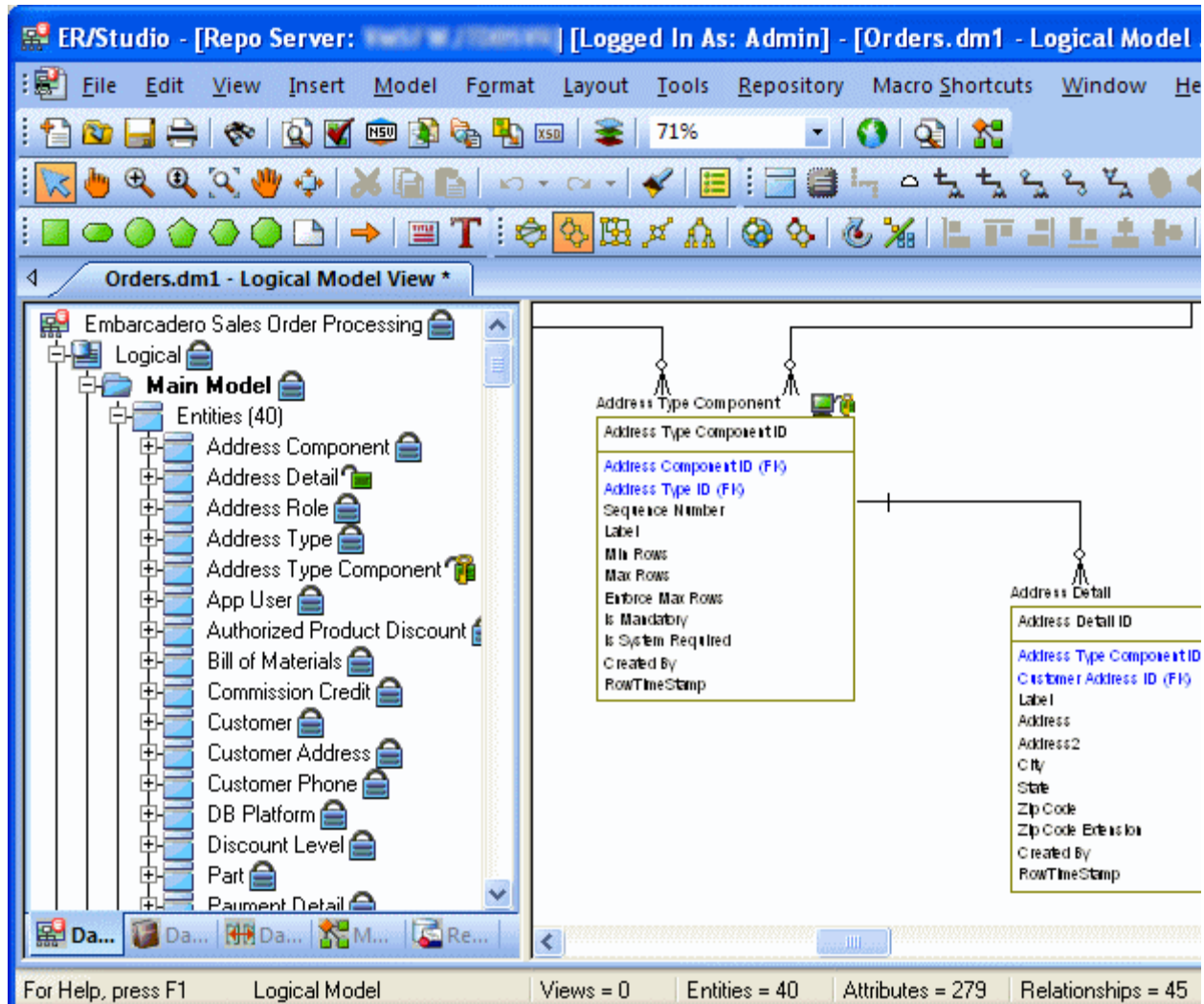

ORGANIZING DIAGRAMS THROUGH THE REPOSITORY PROJECT CENTER

Projects offer a way to organize your diagrams into groups. This organization will become evident when you or anyone else selects Get Diagram to view the contents of the Repository while accessing a diagram. Projects are used to group ER/Studio diagrams and enterprise data dictionaries managed in the Repository. Projects allow for security to be enforced at the project level to all diagrams managed in the Repository. For example, you can apply No Access permissions to all diagrams in a project for a specific user or role. You can organize projects by subject matter, such as Sales Diagrams and HR Diagrams, or you can organize projects by the groups who will be working on the diagrams in the project, such as DBA Diagrams and DA Diagrams. Projects can be added, edited and deleted by choosing Repository > Project Center.

Let's create a project for the newly added Orders data model.

- 1 Choose **Repository > Project Center** and then click **New**.

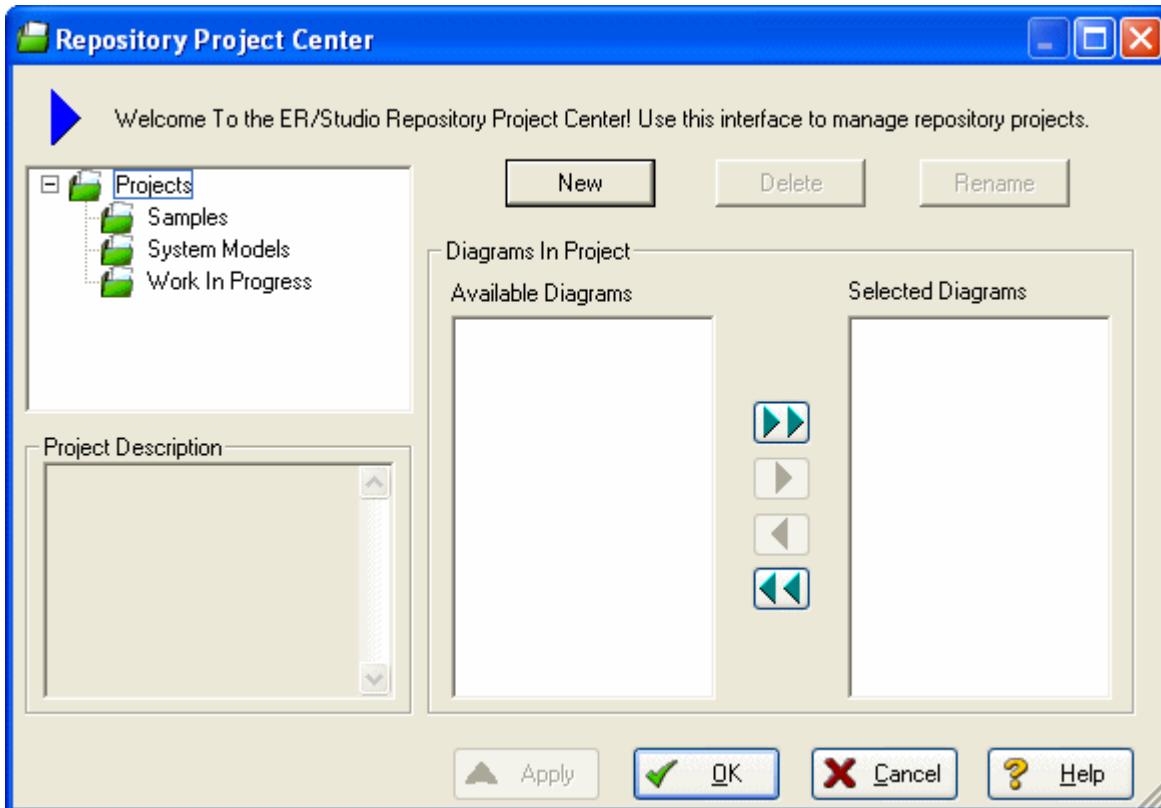

- 2 In the **Name** field, enter `Sales Order Diagrams`.
- 3 In the **Description** field, type a description for the project and then click **OK**.
- 4 In the **Repository Project Center** dialog, click `Orders.dm1`, and then click the right arrow to move `Orders.dm1` to **Selected Diagrams**.
- 5 Click **OK**.

TIP: The Repository supports nested projects. You can create a nested project under the Sales Order Diagrams project by selecting it and then clicking New. The new project will appear under the Sales Order Diagrams folder.

CHECKING OUT DIAGRAMS VS. CHECKING OUT OBJECTS

ER/Studio® Data Architect Repository's management of diagrams is similar to source code control systems you may use for document or source code management. The difference is the degree to which ER/Studio® Data Architect can allow for object check out and team collaboration. Each and every element in an ER/Studio® Data Architect diagram can be individually checked out; starting from the entire diagram itself, down to individual elements, such as entities, managed in a diagram. There are two check out modes that can be used depending on how you want to work on the diagrams, models, and model objects.

- **Exclusive Checkout** – This is a very restrictive and secure mode and will lock the objects that are checked out within the Repository, so that no remote users can work on or more specifically check out the same object at the same time.
- **(Non-Exclusive) Checkout** – Checking out an object 'normally' will allow multiple team members to work collaboratively on the same elements at the same time. Objects can be simultaneously checked out by two or more users. Any conflict will be resolved with the advanced Review Changes dialog.

Assume for the remainder of this session that Exclusive Lock Out is not required. Let's look at a selection of Check Out scenarios:

CHECKING OUT AT THE OBJECT LEVEL

You can check out individual objects by right-clicking on the object in the explorer tree or double clicking on the object in the diagram.

- 1 With the Orders model open, In the Data Model Explorer navigate to the **Customer** entity.
- 2 In the Data Model Window, double-click the **Customer** table.

You will be prompted to check out the table.

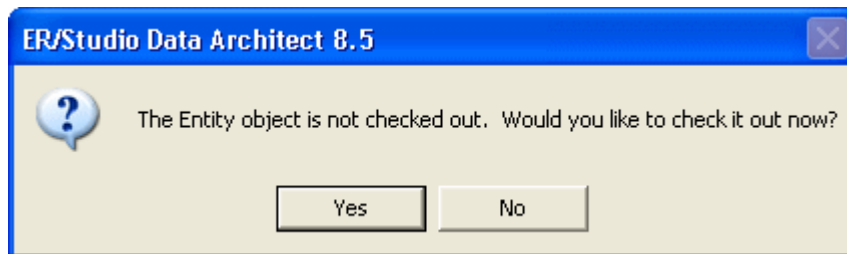

3 Click **Check Out**.

Once the editor opens, the status icon in the Data Model Explorer changes to indicate that you have checked out the object locally to work on it.

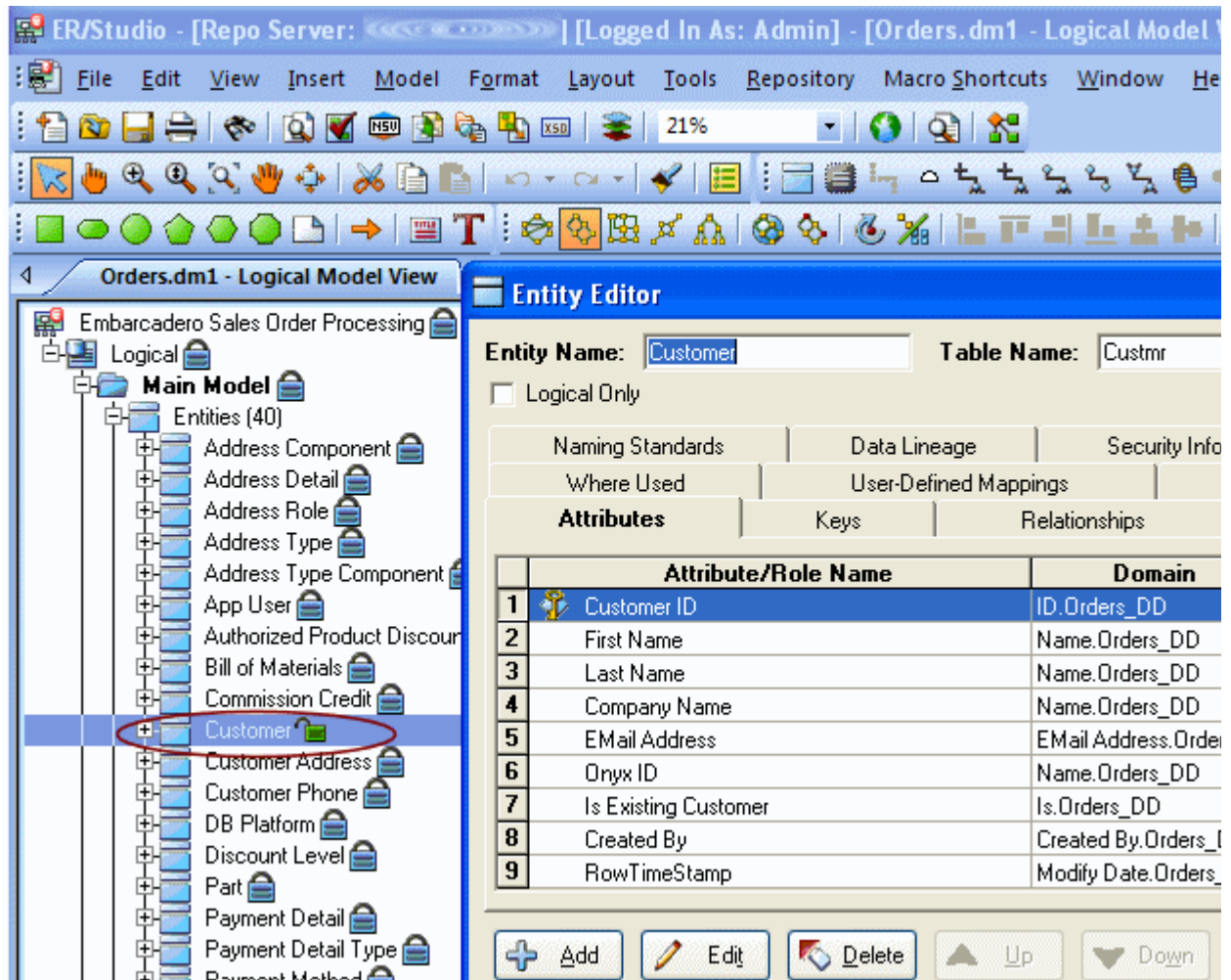

4 In the Entity Editor, rename the **Last Name** attribute to Last Name_Change and then click **OK**.

- 5 In the Data Model Explorer, right-click **Customer** and then from the shortcut menu, select **Check in Object(s)**.

You will be prompted for check in comments and notes as well to review the changes.

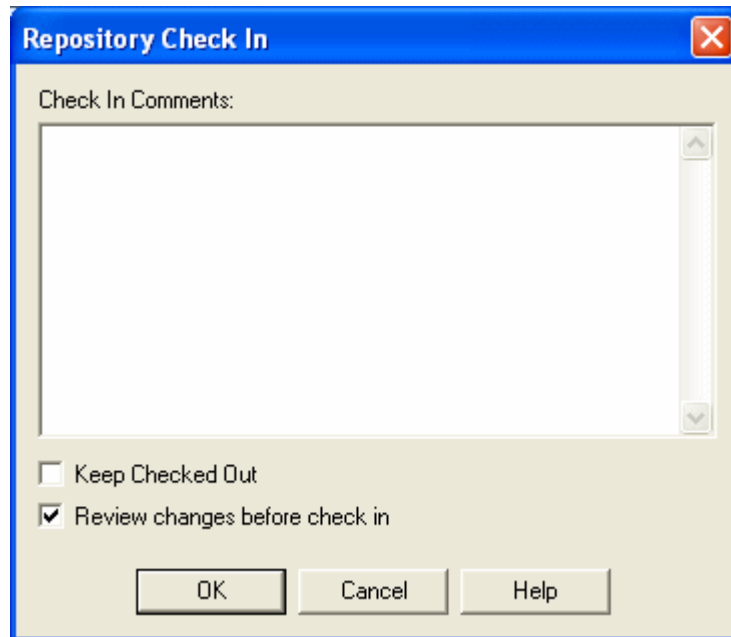

- 6 Select **Review changes before check in** and then click **OK**.

You will be presented with a status of what has changed locally to provide you with an opportunity to report, review and possibly reject changes before check in.

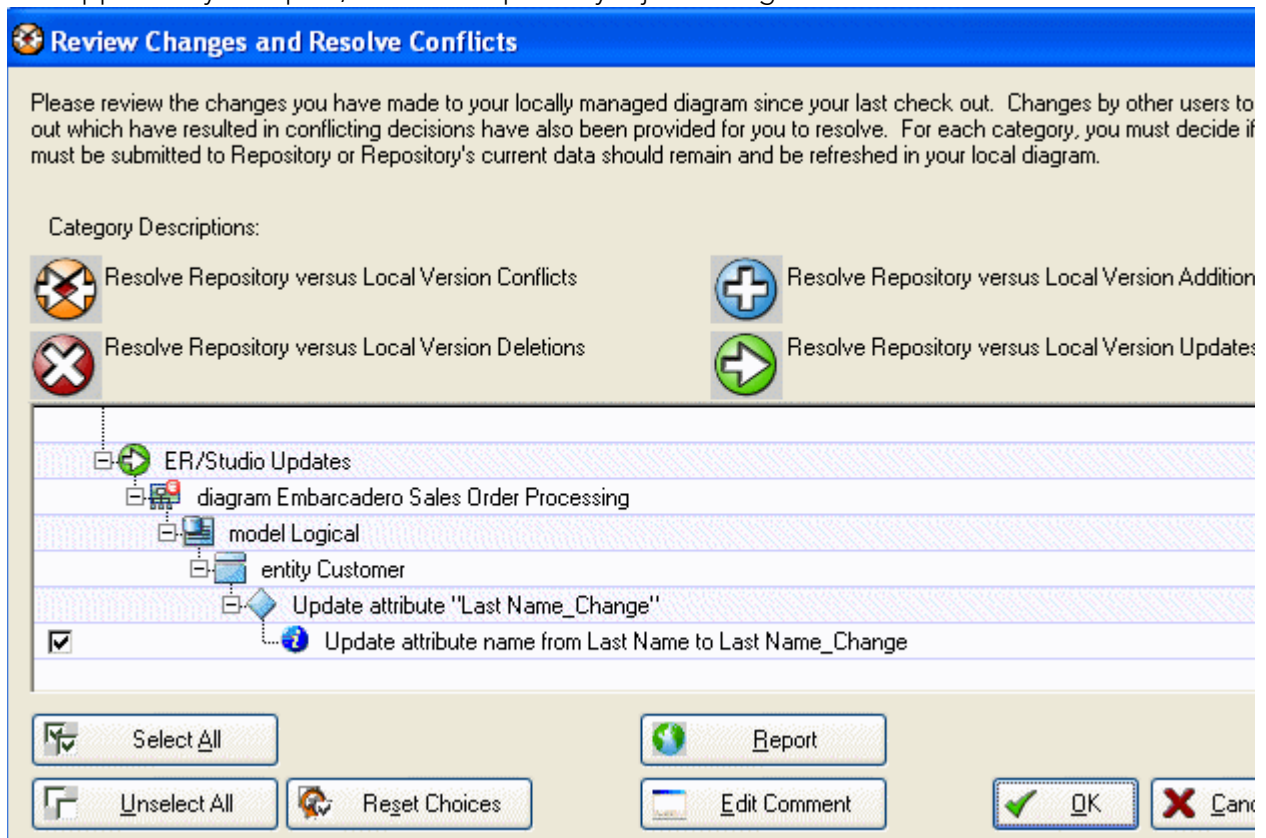

- 7 When finished reviewing the changes, leave the change selected and then click **OK**.

The changes are saved to the Repository.

CHECKING OUT AT THE DIAGRAM LEVEL

In some cases you may want access to the entire ER/Studio® Data Architect diagram. For example, you may need to derive a new physical model from the logical. In this case you will need to check out the entire diagram.

- 1 With the `Orders.dm1` diagram we used in the last session open, choose **Repository > Diagrams > Check Out Diagram**.

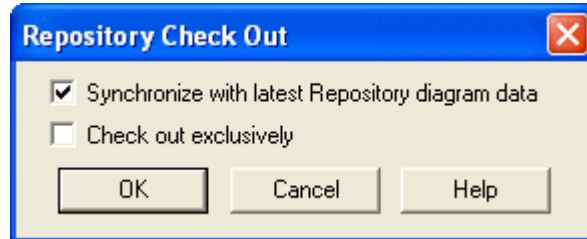

Now let's generate a physical model.

- 2 Choose **Model > Generate Physical Model**.
- 3 Enter a name for the physical model, choose the option to validate the model, and then click through the **Generate Physical Model Wizard**, choosing other options you want.

TIP: You can click Finish at any time in the wizard to accept the defaults.

- 4 Click **Finish**.

The Model Validation Wizard appears.

- 5 In the **Model Validation Wizard**, choose the options you want and then click **Run Validation**.

An entirely new physical model has been generated as seen in the Data Model Explorer.

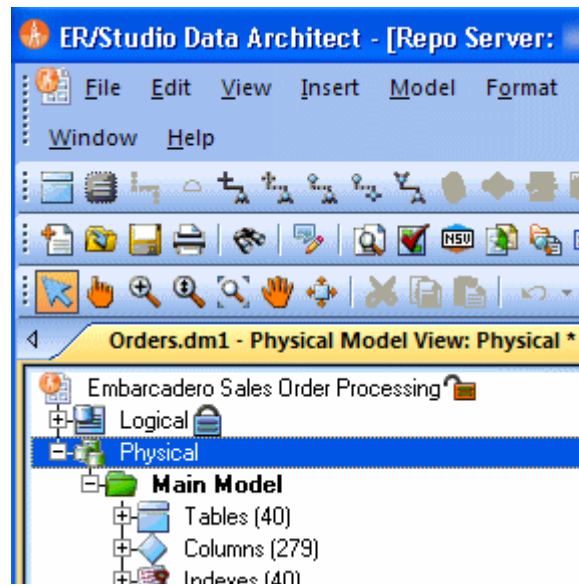

- 6 Choose **Repository > Diagrams > Check In Diagram**.

You will be prompted to enter check in comments and to review your changes.

- 7 Click **OK**.

Your new physical model is saved to the Repository.

CREATING DIFFERENT VERSIONS OF A DIAGRAM

Up until this point we've only added a diagram into the Repository and made a few simple changes. The Repository automatically tracks the changes you and team members are making to the diagram and associates a version with each check in. These versions are located in the version history of each object, which is accessed by right-clicking the object. Assume you want to set frozen baselines of the entire diagram as a mechanism to track milestone releases of the diagram. You can do this by setting a Named Release. Named releases can be used to rollback the diagram back to a previous state if the changes since the last release are not desired.

SETTING A NAMED RELEASE

- 1 With the model from the last session open, choose **Repository > Releases > Set Named Release**.

You will be prompted to check in the diagram.

After checking in the diagram, the **Set Named Release** dialog appears.

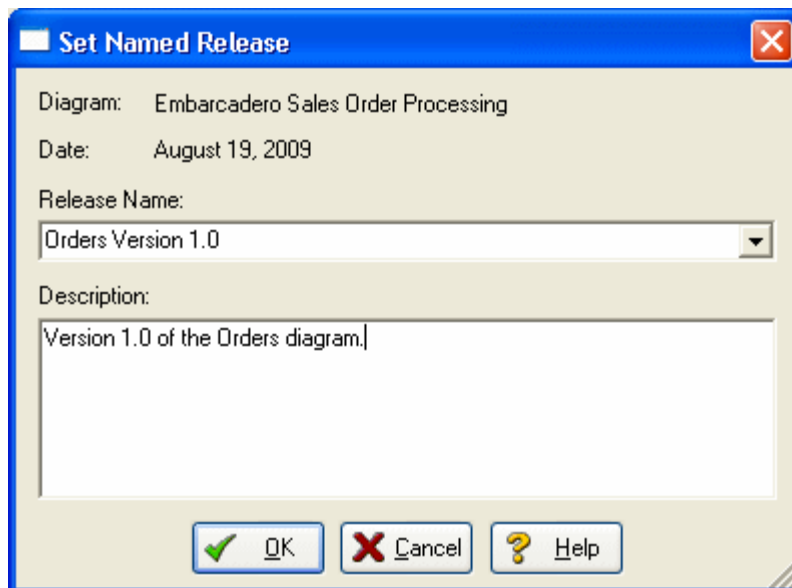

- 2 In the **Release Name** box, enter `Orders - Version 1`.
- 3 In the **Description** box, enter a description of the release.

4 Click **OK**.

The release is stored in the Repository.

TIP: At any time you can access the named release by choosing Repository > Diagrams > Get from Repository interface or Repository > Releases > Get Named Release.

Named releases are denoted with a camera icon:

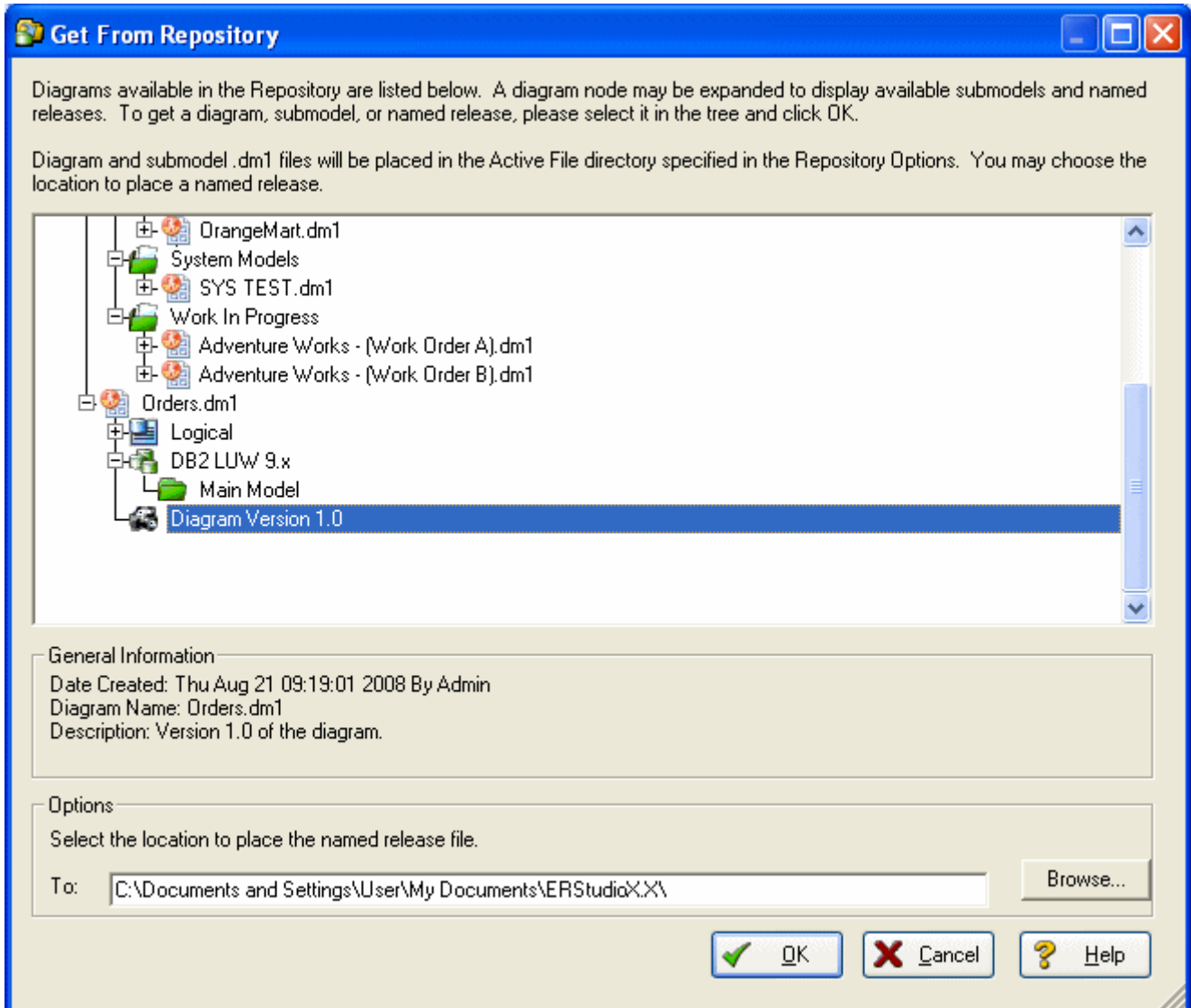

When you get a named release, the diagram will appear with a camera icon on the Data Model Explorer object instead of traditional lock icons. Named release diagrams can be used to roll back and replace an existing diagram or compared against the active diagram to individually roll back changes for certain objects you want.

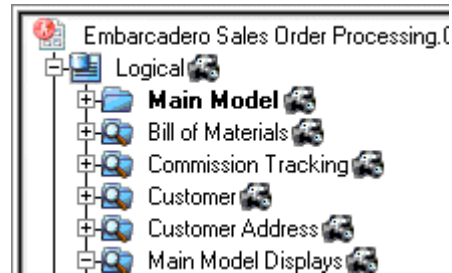

For more information, see “Rolling Back a Diagram to a Previous Version” in the *User Guide*.

APPLYING SECURITY TO DIAGRAMS THROUGH THE SECURITY CENTER

Now that diagrams such as `orders.dm1`, and others you’ll eventually add to the Repository, can be shared across a team, it is a good idea to control who is accessing them. ER/Studio Repository offers a simple to use security center for all of these needs. The Security Center will enable you to create users, roles and apply them selectively to the projects, diagrams, specific models within diagrams, and data dictionaries in the Repository. Let’s look at each more closely.

CREATING A REPOSITORY USER

Before anyone else can log in and begin using ER/Studio Repository, you need to create instances of Users. To set up individual users, follow these steps:

- 1 To launch the Security Center, choose **Repository > Security > Security Center**.
- 2 Click the **Manage Users** tab and then click **New**.

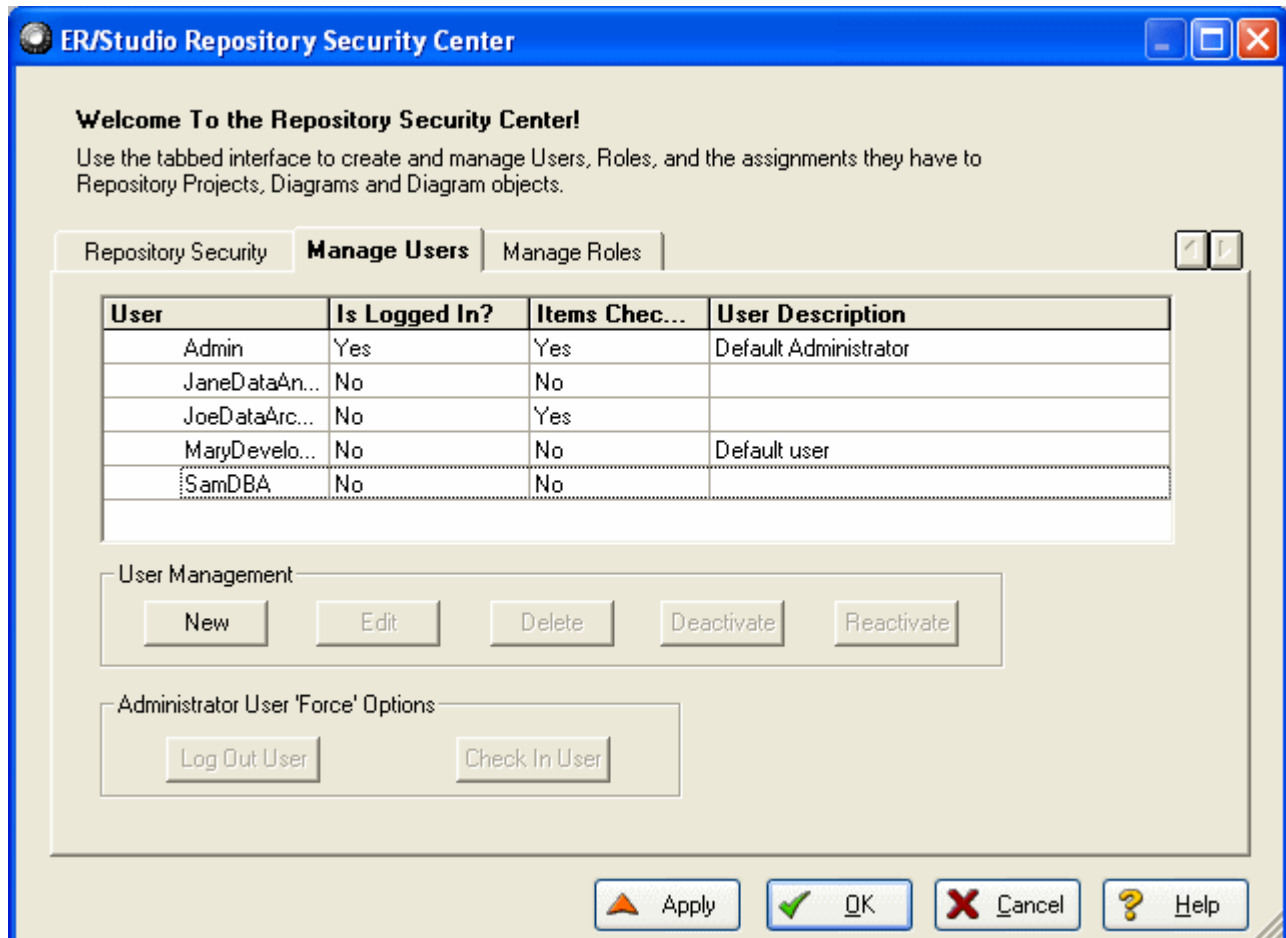

- 3 Enter `user1` as the name for this sample user, and then type a password and a description for the new user.
- 4 On the **Create Repository User** dialog, click **OK**.

Now that you are back in the Security Center, note that `user1` has been created locally, but has not yet been submitted to the Repository. You can see this is the case because there is a star next to the user.

- 5 To submit the changes to the Repository, click **Apply**.

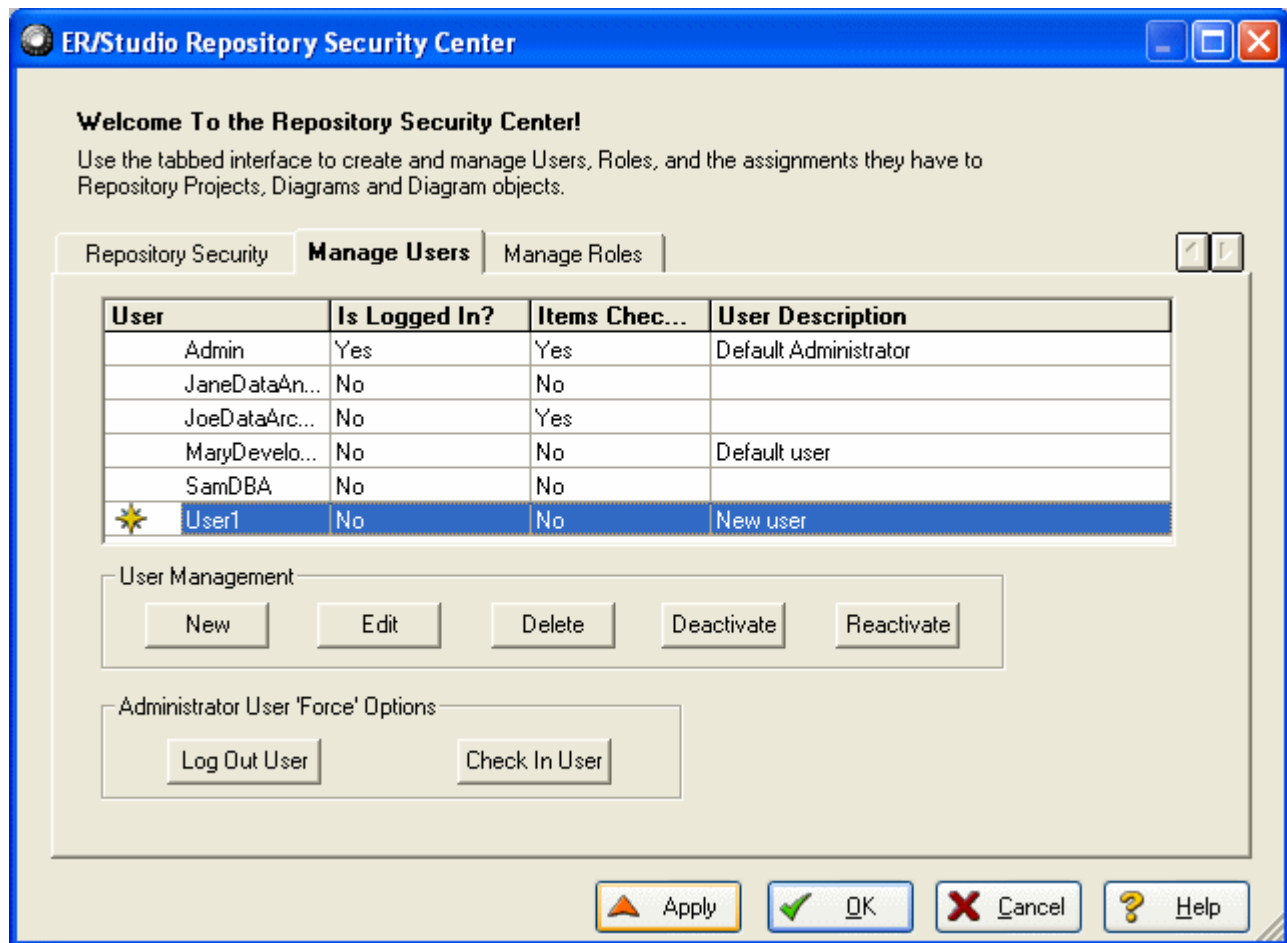

TIP: The Apply feature will allow you to send incremental updates to the Repository while continuing to work in the Security Center.

- 6 Keep the Security Center open for the next procedure.

With user1 created and submitted to the Repository, let's move on to creating a role.

CREATING A ROLE

Now that our user is built, we need to build a package of permissions for the user through the Repository's Roles to allow or prevent certain activities to be performed against objects in the Repository. We do this by creating a Role on the Manage Roles tab of the Security Center.

In this example, let's assume we want to create a role for all data architects in the organization. Let's assume data architects have permissions to create, manage and modify logical models, but have no rights to modify physical (DBMS-specific) models.

- 1 To launch the Security Center, choose **Repository > Security > Security Center**.
- 2 Click the **Manage Roles** tab.

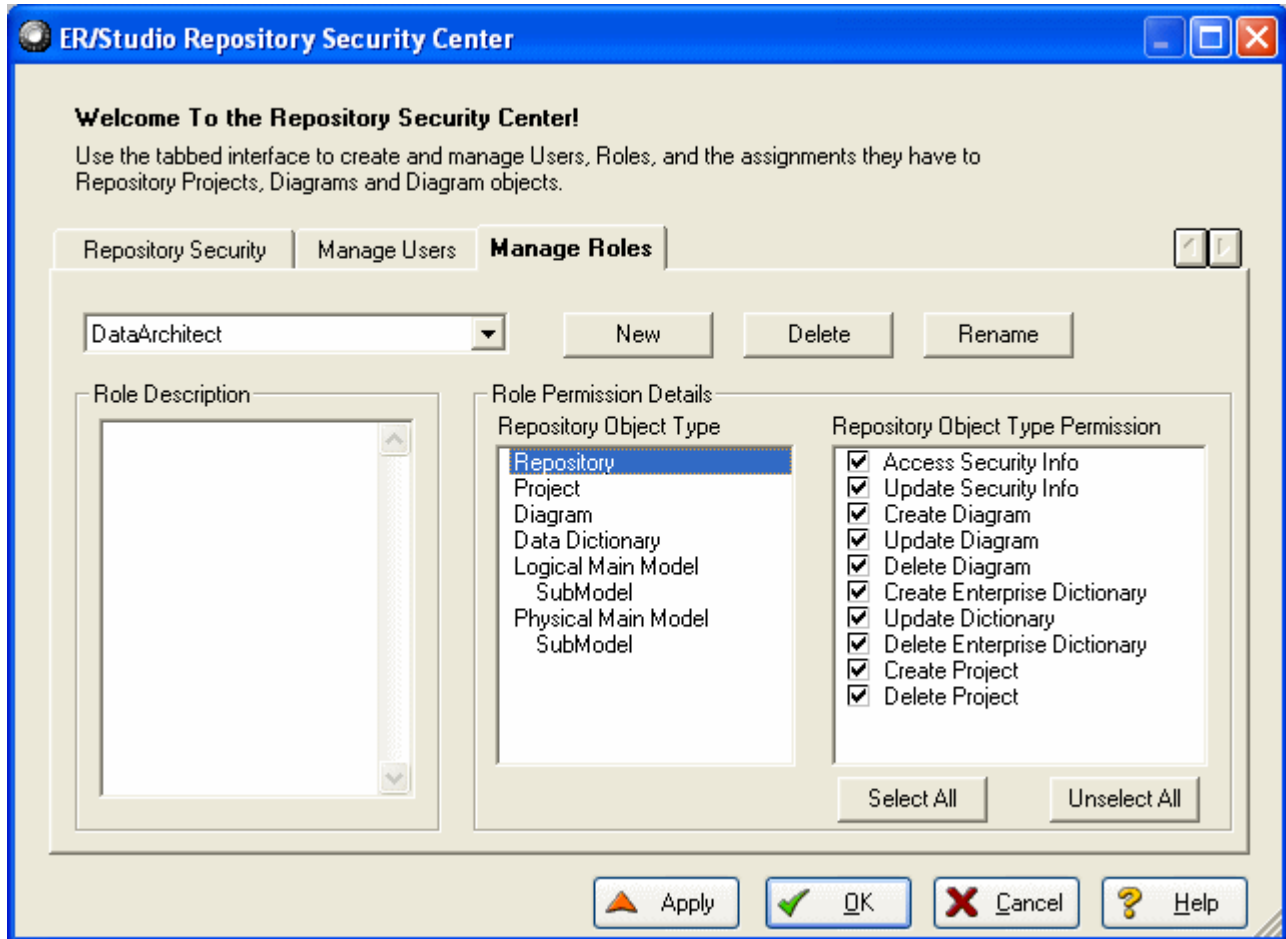

- 3 Click **New**.

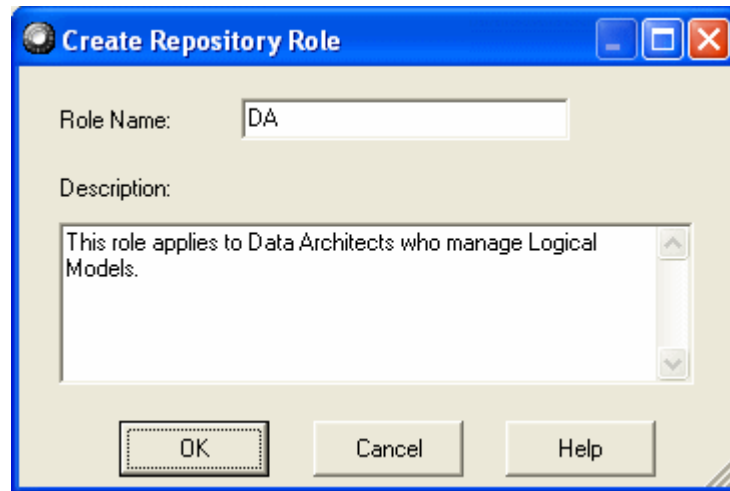

- 4 Enter a name such as **DA**, and provide a description of the role.
- 5 To return to the **Repository Security Center**, click **OK**.

With the initial DA Role created, we now need to build a permission set for it.

- Set permissions for each Repository object type, beginning with the Repository itself.

This is done under the Role Permission Details.

As an example of permissions to set, you may not want DAs to access or modify anything in the Security Center, so you may choose not to select those options as follows:

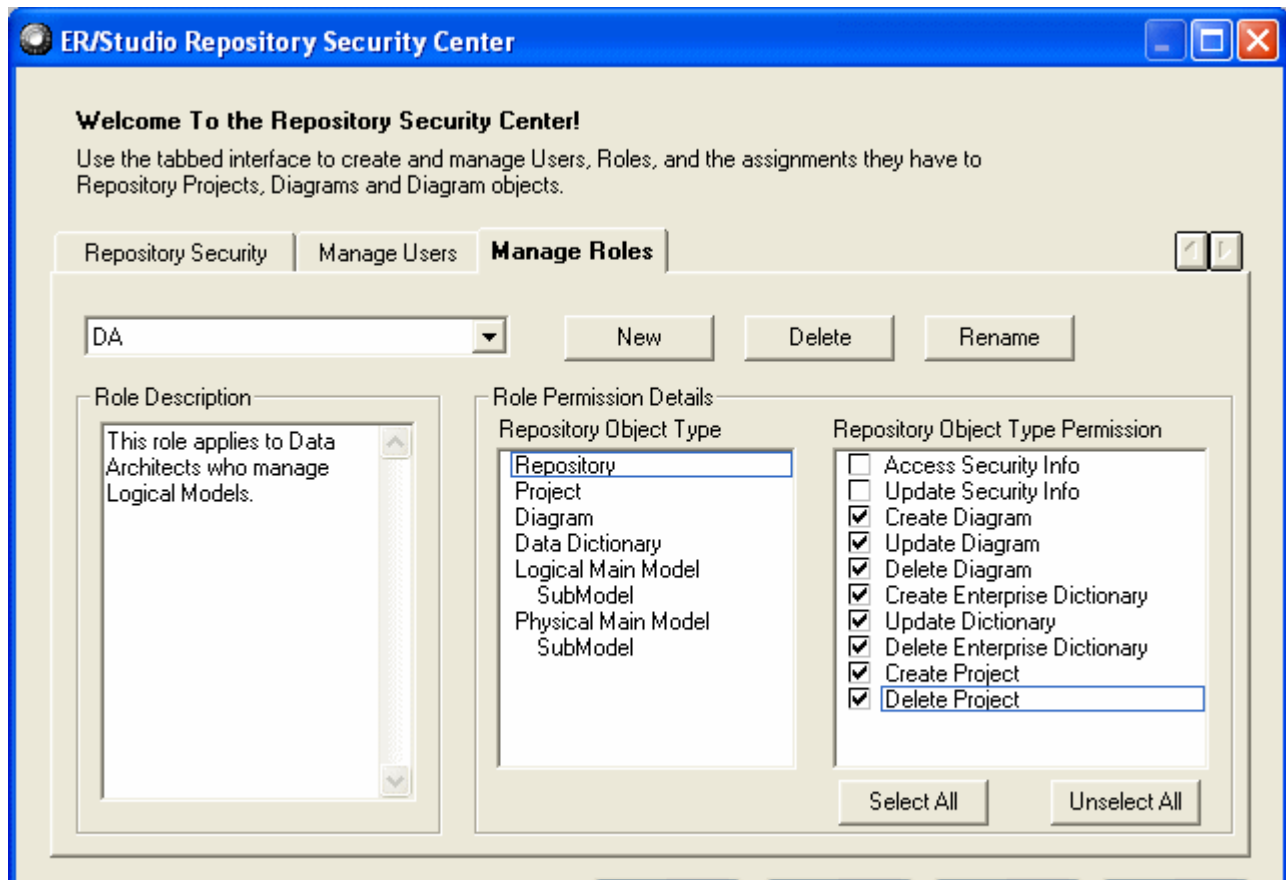

- Continue to assign permissions for the rest of the object types, **Project**, **Diagram**, **Data Dictionary**, **Logical Main Model**, and the **Submodel** of the Logical Main Model.

As mentioned before, the DA should have no rights or privileges to modify physical models, so leave all the options for Physical Main Model and Submodel unselected.

- To save the changes to the Repository, click **Apply**.
- Keep the **Security Center** open for the next procedure.

With the DA Role created and submitted to the Repository, let's move on to binding the User and Role with specific Diagrams in the Repository.

APPLYING PERMISSIONS TO MODELS, DIAGRAMS, AND DICTIONARIES

Now that we have created a User, user1, and a Role, DA, we must now decide to which diagrams or parts of diagrams we want to authorize these users to access. This is done under the Security Center's Repository Security tab.

- 1 Click the **Repository Security** tab.

You will see the Orders diagram within the Sales Order Diagrams project you created earlier. Expand this node and select the Logical Model node as you see here:

- 2 Grab **user1** from **Available Users** and drag it on top of the **DA** role you created.

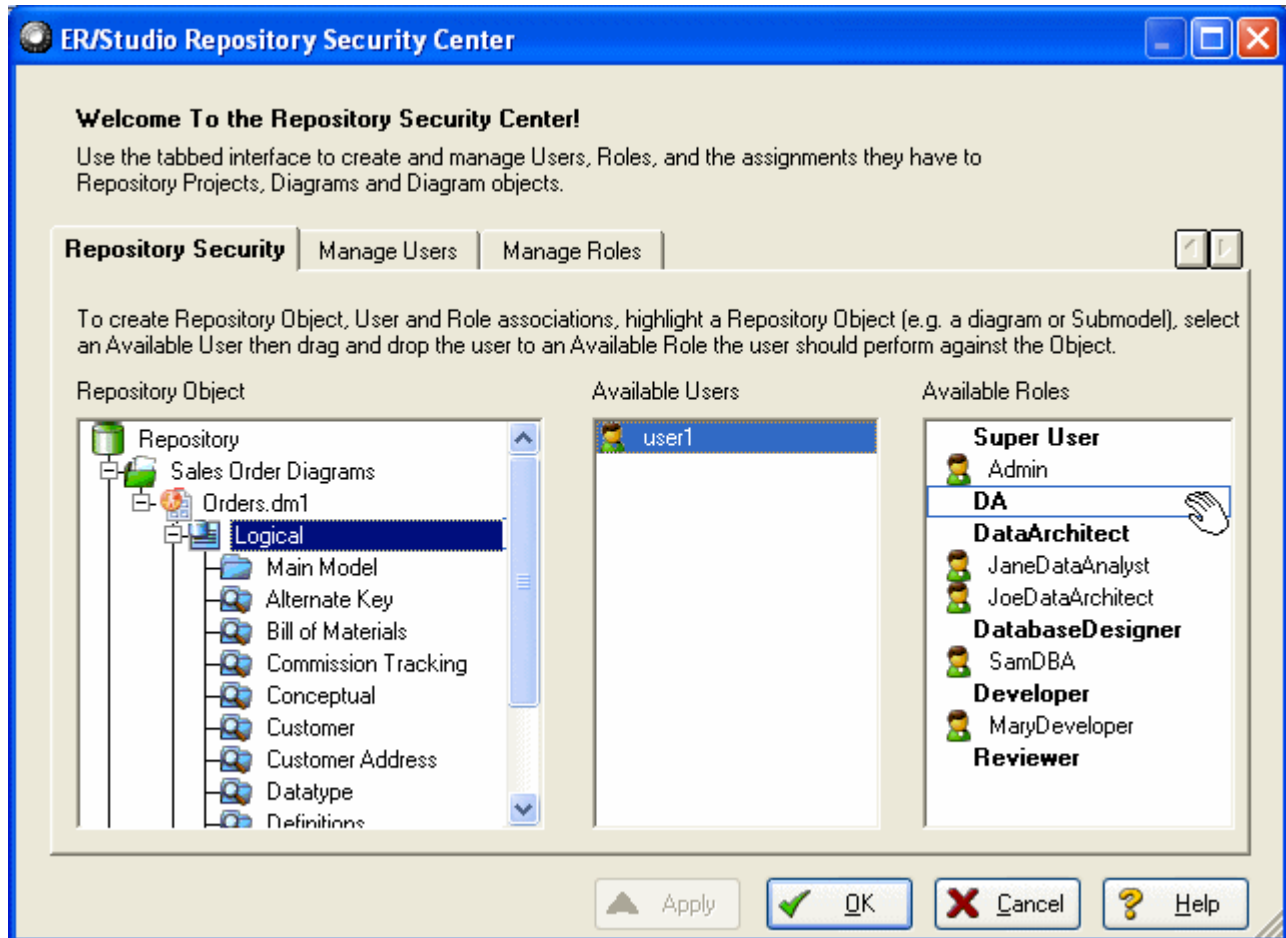

This will give user1 the DA permissions you set when creating the Role on the Orders logical model and all its Submodels.

- 3 If you want this user to have access to the Data Dictionary associated with the Orders.dm1 file, in the **Repository Object** section, select the **Orders_DD** data dictionary, grab **user1** from **Available Users** and then drag it over on top of **DA**.
- 4 Click **Apply**.

Finished! When user1 logs into the ER/Studio Repository, user1 will have only the rights and privileges that were created in the DA role. Do this for other diagrams you eventually add to the Repository.

Conclusion

At this point we have finished the Repository portion of the tutorials. This should have given you a good start to continue working with your diagrams in a collaborative environment. You should now know how to apply security to diagrams, version diagrams, check in and out portions of diagrams, and reuse common data elements.

ADDITIONAL EVALUATION RESOURCES

Embarcadero Technologies provides a variety of resources to help support your evaluation and selection of a Data Modeling product for your organization.

Web site

Visit our Web site for current product and company information, educational materials and supporting information. Visit www.embarcadero.com.

To download an evaluation copy of ER/Studio, please visit: www.embarcadero.com/downloads/

Electronic Documentation

Detailed reference documentation is available on the ER/Studio Evaluation CD or online at docs.embarcadero.com

Online FAQ

The ER/Studio online FAQ provides answers to commonly asked questions regarding licensing, installation and other helpful topics.

To review the FAQs for ER/Studio visit: www.embarcadero.com/products/er-studio/faq

Email Support

You can contact ER/Studio support engineers, consultants and engineers directly by sending inquiries to:

For North America, Latin America and Asia Pacific:

support@embarcadero.com

For Europe, Africa and the Middle East:

uk.support@embarcadero.com

or log a case through embarcadero.com at: www.embarcadero.com/support/open_case.jsp

Telephone Support

We encourage you to call us anytime you would like help or have questions during your evaluation.

For North America, Latin America and Asia Pacific:

Phone: 415.834.3131 x2

Hours: Monday to Friday, 6:00am - 6:00pm Pacific time

For Europe, Africa and the Middle East

Phone: +44 (0) 1628 684499

Hours: Monday to Friday, 9:00am to 5:30pm UK time

Request a Product Key

For North America, Latin America and Asia Pacific:

key@embarcadero.com

For Europe, Africa and the Middle East:

uk.key@embarcadero.com